

SILICONA | EPDM | SBR | NBR | TPE | CEDULARES | CR | FKM | FFKM

Perfiles | Juntas | Materias Primas | Pavimentos

Piezas al corte | Troqueladas | Moldeadas

# ECATEC

ELABORADORA DE CAUCHOS TÉCNICOS



# CATÁLOGO

## CATÁLOGO GENERAL

ECATEC.ES

*Perfilamos tus ideas*



**ECATEC**

ELABORADORA DE CAUCHOS TÉCNICOS

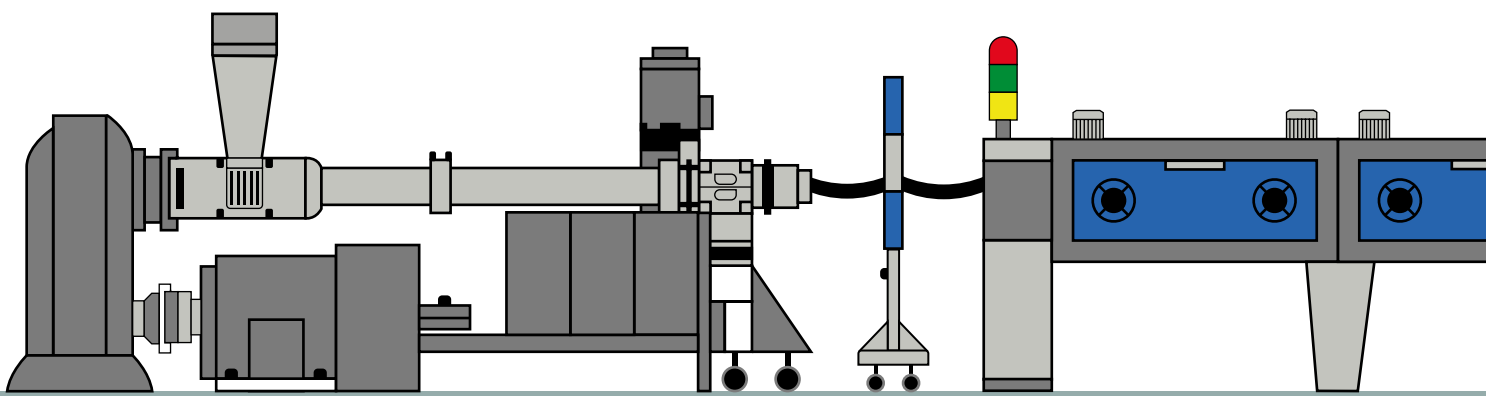

○ MATERIALES	6	Ⓐ PERFILES PARA CONTAINER BASURA	22
≡ JUNTAS DE EVACUACIÓN DE GASES Y HUMOS	10	⚡ PERFILES DE COEXTRUSIÓN	23
~ JUNTAS PARA TUBERÍAS	12	⓪ DEFENSAS FORMA D	24
≡ JUNTAS DE VENTILACIÓN DE GASES Y HUMOS	12	Ⓜ PERFILES FORMA e	25
⤴ JUNTAS DE ESTANQUEIDAD PARA BIDONES	13	└ PERFILES FORMA L O CANTONERA	26
⓪ JUNTAS HINCHABLES	15	⓪ PERFILES MEDIA CAÑA	28
└ JUNTAS DE ESTANQUEIDAD PARA VÁLVULAS DE COMPUERTAS	16	∞ PERFILES PARA PISTAS DE HIELO	34
Ⓒ PERFILES CON ARMA METÁLICA	17	⊥ PERFILES FORMA T	35
Ⓞ PERFILES PARA ABRAZADERAS GÁSMICAS, METÁLICAS E ISOFÓNICAS	18	▲ PERFILES TRAPECIO ISÓSCELES Y ESCALENO	37
⤴ PERFILES PARA CABALLETE CRISTAL / JUNQUILLO	19	Ⓜ PERFILES FORMA U	39
⤴ PERFILES PARA CIERRE DE PUERTAS Y VENTANAS	20	Ⓞ PERFILES FORMA 9 O NOTA MUSICAL	53
└ PERFILES PARA CARROCERÍAS	21	↪ PERFILES VARIOS	56

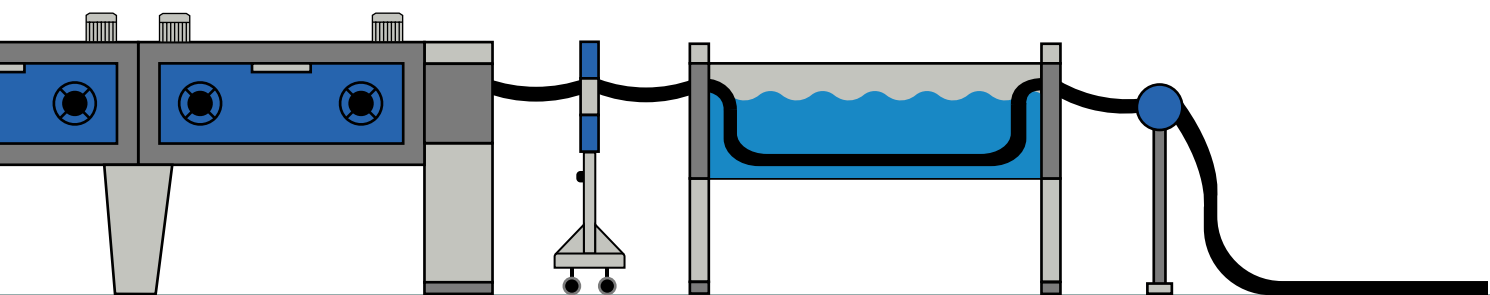

## MATERIALES

### Caucho etileno-propileno-dieno EPDM

Tipo de caucho sintético utilizado para una amplia gama de aplicaciones como automoción, construcción, juntas industriales, etc.

Las membranas de caucho EPDM tienen gran resistencia a cambios de temperatura bruscos, al envejecimiento, al ozono y a numerosos productos químicos corrosivos. Resistencia a muchos ácidos, álcalis, detergentes, cetonas, alcoholes y glicoles y elevadas propiedades mecánicas.

Así mismo se pueden conseguir formulaciones con elevados niveles de aislamiento eléctrico, ignifugabilidad de grado medio o que permiten el contacto con agua potable. El caucho EPDM estándar es negro de 65 Shore.

#### PROPIEDADES

Dureza (Shore A)	Trabajo (°C)	Tolerancias	Colores	Aplicaciones	Certificaciones
50 a 85	-45 a 120	ISO 3302-1996 (E) E AND L CLASS EXTRUSION ISO 3302-1996 (E) M-CLASS CLASS MOLDEO	Negro Blanco Gris	Automoción Construcción Sector eléctrico Juntas industriales Tuberías Suministros	

### Caucho cedular SBR-NBR

El Caucho Cedular se produce de elastómeros de base de caucho natural y/o sintético con la adición de agentes esponjantes. El EPDM cedular debe esta esponjosidad a las cédulas de aire que se encapsularon en el momento de su fabricación, tiene buena resistencia a la compresión y a la deformación permanente.

Es hermético y estanco (cédula cerrada). Ámbitos de aplicación del caucho cedular: juntas de estanqueidad de aire, agua fría y caliente, polvo, aceites y grasas, ácidos y bases diluidas, rayos U.V, ozono. También se utiliza en aislamiento acústico y vibración.

El EPDM cedular estándar es en color negro con una densidad de 0,70 gr/cm<sup>3</sup>.

#### PROPIEDADES

Dureza (Shore A)	Trabajo (°C)	Tolerancias	Colores	Aplicaciones	Certificaciones
0.4 a 0.9	-30 a 100	ISO 3302-1996 (E) E AND L CLASS EXTRUSION ISO 3302-1996 (E) M-CLASS CLASS MOLDEO	Negro Beige	Se pueden utilizar prácticamente en todos los ámbitos de la industria, para sellar, retener, aislar y amortiguar.	

## Caucho silicona VMQ-PVMQ

El caucho de silicona es un derivado de la roca de cuarzo combinado a altas temperaturas con carbono. Es considerado buen aislante eléctrico y en contacto con llamas arde con dificultad.

Presentan una excelente resistencia al aire caliente y una flexibilidad extrema a bajas temperaturas. Es extraordinaria su resistencia al ozono, intemperie, ambientes salinos y radiación ultravioleta.

Siliconas disponibles de producción: silicona estándar aislante (MVQ), silicona conductora, silicona para tratamiento corona, silicona para vapor, fluoro silicona (FVMQ), silicona para muy altas temperaturas (THT), silicona para muy bajas temperaturas (PMVQ), silicona platino. La silicona estándar es traslúcida de 65 Shore A

### PROPIEDADES

Dureza (Shore A)	Trabajo (°C)	Tolerancias	Colores	Aplicaciones	Certificaciones
25 a 85	-70 a 220	ISO 3302-1996 (E) E AND L CLASS EXTRUSION  ISO 3302-1996 (E) M-CLASS CLASS MOLDEO	Cualquier color, siguiendo la carta RAL o PANTONE	Generalmente son juntas de estanqueidad, para todo tipo de industrias, especialmente las de los fabricantes de maquinaria.	Farmacopea Europea 3ª edición USP XXV Clase VI Ausencia de transferencia de sabor, FDA (CFR21 sección 177.2600, etc.)

## Caucho silicona cedula

La silicona cedula o también llamada silicona esponjosa debe esta característica a las cédulas de aire que se encapsularon en el momento de su fabricación, tiene buena resistencia a la compresión y a la deformación permanente. Proporciona una excelente adaptabilidad a superficies irregulares o que han sufrido algún desgaste y disminuye su conductividad térmica.

Este material es usado en juntas de estanqueidad, industria alimentaria, automoción, juntas de aislamiento, etc. No se aconseja el contacto con grasas y aceites. La silicona cedula estándar es en color blanco roto o negro con una densidad de 0,25 gr/cm3.

### PROPIEDADES

Dureza (Shore A)	Trabajo (°C)	Tolerancias	Colores	Aplicaciones	Certificaciones
10 a 35	-50 a 200	ISO 3302-1996 (E) E AND L CLASS EXTRUSION ISO 3302-1996 (E) M-CLASS CLASS MOLDEO	Cualquier color, salvo traslúcido, siguiendo la carta RAL o PANTONE	Se pueden utilizar prácticamente en todos los ámbitos de la industria, para sellar, retener, aislar y amortiguar.	Farmacopea Europea 3ª edición USP XXV Clase VI Ausencia de transferencia de sabor, FDA (CFR21 sección 177.2600, etc.)

## MATERIALES

### Caucho estireno-butadieno Rubber SBR

Presenta moderada resistencia al desgarro, ozono y a la intemperie, por tener las cadenas moleculares insaturadas. El caucho SBR tiene buena resistencia química a productos químicos inorgánicos, pero no a los ácidos oxidantes, limitada a los ácidos minerales, no siendo adecuada para líquidos orgánicos en general.

Este material es idóneo para juntas de estanqueidad. El caucho SBR estándar es negro de 65 Shore A.

#### PROPIEDADES

Dureza (Shore A)	Trabajo (°C)	Tolerancias	Colores	Aplicaciones	Certificaciones
60 a 70	-50 a 90	ISO 3302-1996 (E) E AND L CLASS EXTRUSION ISO 3302-1996 (E) M-CLASS CLASS MOLDEO	Negro Blanco Gris Beige	Juntas	

### Caucho nitrilo-butadieno Rubber NBR

Es un tipo de caucho sintético, su principal característica es la resistencia a los aceites, además tiene buenas propiedades mecánicas como tracción, compresión, flexión, e impermeabilización a los gases. Presenta una buena adhesividad al acero y presenta un moderado envejecimiento. No se recomienda para hidrocarburos, clorinados, acetonas y otros agentes oxidantes.

Su combinación con PVC mejora su pobre resistencia al ozono y a la intemperie y hace posible que pueda ser aplicado a exteriores. El caucho NBR estándar es negro de 70 Shore A. El caucho NBR estándar es negro de 70 Shore A.

#### PROPIEDADES

Dureza (Shore A)	Trabajo (°C)	Tolerancias	Colores	Aplicaciones	Certificaciones
60 a 80	-40 a 100	ISO 3302-1996 (E) E AND L CLASS EXTRUSION ISO 3302-1996 (E) M-CLASS CLASS MOLDEO	Negro	Automoción en tubos de conducción de gasolina, juntas y retenes y en general todo aquello que tiene permanente contacto con aceites.	



## Termoplástico vulcanizado TPV

Los Termoplásticos vulcanizados dinámicamente (TPV) son un tipo especial de termoplásticos elastómeros (TPE) con los que se obtienen mejores propiedades debido al exclusivo sistema de mezclado que consigue vulcanizar dinámicamente una fase discreta de elastómero inmersa en una fase continua de termoplástico

TPV Elastoprene es un material completamente reciclable y reutilizable en el punto de transformación, siendo respetuoso con el medio ambiente y mejorando la rentabilidad de los procesos, lo que representa una ventaja añadida sobre las piezas y procesos de goma. TPV Elastoprene tiene buena resistencia al ozono, UV y al ataque de diversos productos químicos, mientras que presenta una temperatura de servicio de hasta 125°C

### PROPIEDADES

Dureza (Shore A)	Trabajo (°C)	Tolerancias	Colores	Aplicaciones	Certificaciones
60 a 67	170 a 200	ISO 868 ISO 815	Negro	Perfiles de estanqueidad extruídos y co-extruídos. productos con acabados en flock, cintas adhesivas	

## Termoplástico TPE

El TPE es un material de tipo caucho que se puede procesar con tecnologías termoplásticas como el moldeo por inyección, el moldeo 2K o la extrusión. Los elastómeros termoplásticos (TPE) son compuestos de materiales termoplásticos como PP, PBT o PA combinados con material de caucho suave y, a menudo, la incorporación de aditivos como aceites o cargas.

Son una clase de polímeros o mezcla física de polímeros (generalmente un plástico y un caucho) que dan lugar a materiales con características termoplásticas y elastoméricas, además son reciclables, puesto que, al igual que los termoplásticos en general, pueden ser reutilizados después de ser transformados. Tienen características elásticas típicas de los cauchos, pero estos no son reciclables por temperatura, debido a su carácter entrecruzado que le impide fundirse al calentarlo.

### PROPIEDADES

Dureza (Shore A)	Trabajo (°C)	Tolerancias	Colores	Aplicaciones	Certificaciones
60 a 67	170 a 200	ISO 868 ISO 815	Negro	Perfiles de estanqueidad extruídos y co-extruídos. productos con acabados en flock, cintas adhesivas	



**10002093**

Alto	Ancho	Formato
4,4mm	5,8mm	CR200m

Material	SILICONA 65° NEGRA
----------	--------------------

**10001797**

Alto	Ancho	Formato
3,5mm	7mm	CR200m

Material	SILICONA 65° AZUL
----------	-------------------

**10002107**

Alto	Ancho	Formato
6mm	7,8mm	CR200m

Material	SIL. 65° HT ROJO VIVO
----------	-----------------------

**10001754**

Alto	Ancho	Formato
6mm	7,8mm	CR200m

Material	SIL. 65° ROJO VIVO
----------	--------------------

**10002094**

Alto	Ancho	Formato
5mm	7,8mm	CR200m

Material	SIL. 65° HT ROJO VIVO
----------	-----------------------

**10001913**

Alto	Ancho	Formato
5,5mm	8mm	CR200m

Material	SILICONA 65° NEGRA
----------	--------------------

**10002111**

Alto	Ancho	Formato
6,4mm	8mm	CR200m

Material	SIL. 50° HT AZUL
----------	------------------

**10004037**

Alto	Ancho	Formato
6,4mm	8,2mm	CR200m

Material	SILICONA 70° NEGRA
----------	--------------------

**10001182**

Alto	Ancho	Formato
3,5mm	8,5mm	CR200m

Material	SILICONA 65° VERDE
----------	--------------------

**10000678**

Alto	Ancho	Formato
3,9mm	8,5mm	CR200m

Material	SIL. 65° ROJO TEJA
----------	--------------------

**10000999**

Alto	Ancho	Formato
5,8mm	8,8mm	CR200m

Material	SIL. 65° ROJO TEJA
----------	--------------------

**10001043**

Alto	Ancho	Formato
5mm	8,9mm	CR200m

Material	SILICONA 65° AZUL
----------	-------------------

**10000926**

Alto	Ancho	Formato
5mm	8,9mm	CR200m

Material	SIL. 65° ROJO VIVO
----------	--------------------

**10000677**

Alto	Ancho	Formato
5mm	9mm	CR200m

Material	SILICONA 65° NEGRA
----------	--------------------

**10000679**

Alto	Ancho	Formato
4,25mm	9,5mm	CR200m

Material	SILICONA 65° NEGRA
----------	--------------------

**10002092**

Alto	Ancho	Formato
5mm	9,75mm	CR200m

Material	EPDM 70° NEGRO
----------	----------------



**10004139**

Alto	Ancho	Formato
6,2mm	9,8mm	CR200m

Material	SILICONA 70° GRIS
----------	-------------------

**10000532**

Alto	Ancho	Formato
6,5mm	10mm	CR200m

Material	SIL. 65° ROJO TEJA
----------	--------------------

**10000680**

Alto	Ancho	Formato
4,1mm	10mm	CR200m

Material	SILICONA 65° NEGRA
----------	--------------------

**10001740**

Alto	Ancho	Formato
5mm	10mm	CR200m

Material	SILICONA 65° VERDE
----------	--------------------

**10003663**

Alto	Ancho	Formato
6mm	10mm	CR200m

Material	SILICONA 65° GRIS
----------	-------------------

**10003416**

Alto	Ancho	Formato
6,2mm	10mm	CR200m

Material	SILICONA 65° VERDE
----------	--------------------

**10001212**

Alto	Ancho	Formato
7,5mm	10mm	CR200m

Material	SILICONA 65° NEGRA
----------	--------------------

**10004024**

Alto	Ancho	Formato
5,9mm	10,57mm	CR200m

Material	SILICONA 70° GRIS
----------	-------------------

**10004025**

Alto	Ancho	Formato
5,9mm	10,57mm	CR200m

Material	EPDM 60° NEGRO
----------	----------------

**10001743**

Alto	Ancho	Formato
7,2mm	11,2mm	CR200m

Material	SILICONA 65° NEGRA
----------	--------------------

**100H1369**

Alto	Ancho	Formato
4mm	11,7mm	CR200

Material	SILICONA 70° NEGRO
----------	--------------------

**10001558**

Alto	Ancho	Formato
6mm	12mm	CR200m

Material	SILICONA 65° GRIS
----------	-------------------

**10001771**

Alto	Ancho	Formato
6,5mm	12mm	CR200m

Material	SIL. 65° ROJO TEJA
----------	--------------------

**10001508**

Alto	Ancho	Formato
7,5mm	12mm	CR200m

Material	EPDM 70° NEGRO
----------	----------------

**10003124**

Alto	Ancho	Formato
6,5mm	19,9mm	CR200m

Material	SILICONA 65° NEGRA
----------	--------------------

**10001514**

Alto	Ancho	Formato
6,7mm	27mm	CR200m

Material	SILICONA 65° NEGRA
----------	--------------------



EPDM / VMQ

## JUNTAS PARA TUBERÍAS

10003946		
Alto	Ancho	Formato
10,4mm	30,8mm	CR200m
Material	SILICONA. 65° GRIS	

10003328		
Alto	Ancho	Formato
7,6mm	20mm	CR200m
Material	SIL. 65° ROJO TEJA	



EPDM / VMQ

## JUNTAS PARA TUBOS Y SISTEMA DE VENTILACIÓN

1003460		
Regata	Alto	Formato
5mm	6,1mm	CR200m
Material	EPDM 70° NEGRO	

A- 165		
Alto	Ancho	Formato
6mm	11,8mm	CR200m
Material	EPDM 70° NEGRO	

A- 166		
Alto	Ancho	Formato
9mm	11mm	CR200m
Material	EPDM 70° NEGRO	

A- 167		
Alto	Ancho	Formato
14,3mm	14,5mm	CR200m
Material	EPDM 70° NEGRO	

A- 168		
Alto	Ancho	Formato
19mm	15,5mm	CR200m
Material	EPDM 70° NEGRO	

B- 129		
Diámetro	Color	Formato
7mm	Negro	Juntas
		
Material	ESP-EPDM 0.60°	

B- 130		
Diámetro	Color	Formato
8mm	Negro	Juntas
		
Material	ESP-EPDM 0.60°	

B- 131		
Diámetro	Color	Formato
9mm	Negro	Juntas
		
Material	ESP-EPDM 0.60°	

B- 132		
Diámetro	Color	Formato
10mm	Negro	Juntas
		
Material	ESP-EPDM 0.60°	

B- 133		
Diámetro	Color	Formato
11mm	Negro	Juntas
		
Material	ESP-EPDM 0.60°	

B- 134		
Diámetro	Color	Formato
12mm	Negro	Juntas
		
Material	ESP-EPDM 0.60°	

B- 135		
Diámetro	Color	Formato
13mm	Negro	Juntas
		
Material	ESP-EPDM 0.60°	

B- 136		
Diámetro	Color	Formato
14mm	Negro	Juntas
		
Material	ESP-EPDM 0.60°	

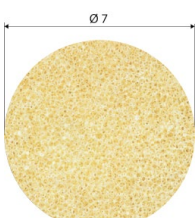
B- 137		
Diámetro	Color	Formato
7mm	Beige	Juntas
		
Material	ESP-EPDM 0.60°	

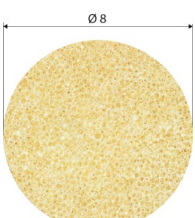
B- 138		
Diámetro	Color	Formato
8mm	Beige	Juntas
		
Material	ESP-EPDM 0.60°	

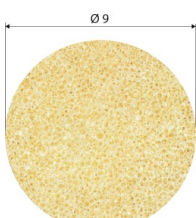
B- 139		
Diámetro	Color	Formato
9mm	Beige	Juntas
		
Material	ESP-EPDM 0.60°	

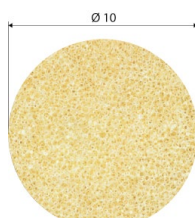
B- 140		
Diámetro	Color	Formato
10mm	Beige	Juntas
		
Material	ESP-EPDM 0.60°	

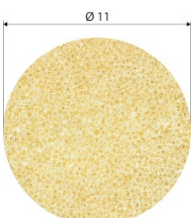
B- 141		
Diámetro	Color	Formato
11mm	Beige	Juntas
		
Material	ESP-EPDM 0.60°	

B- 142		
Diámetro	Color	Formato
12mm	Beige	Juntas
		
Material	ESP-EPDM 0.60°	

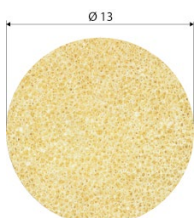
B- 143		
Diámetro	Color	Formato
13mm	Beige	Juntas
		
Material	ESP-EPDM 0.60°	

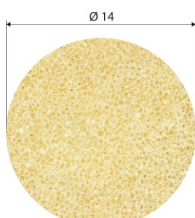
B- 144		
Diámetro	Color	Formato
14mm	Beige	Juntas
		
Material	ESP-EPDM 0.60°	



**A- 137**

Alto	Ancho	Formato
11,3mm	18mm	Juntas

Material	ESP-EPDM 0.60°
----------	----------------

**A- 138**

Alto	Ancho	Formato
19,3mm	26mm	Juntas

Material	ESP-EPDM 0.60°
----------	----------------

**A- 139**

Alto	Ancho	Formato
7,3mm	14mm	Juntas

Material	ESP-EPDM 0.60°
----------	----------------

**10003379**

Alto	Ancho	Formato
13,7mm	14mm	Juntas

Material	ESP-EPDM 0.65°
----------	----------------

**100H1500**

Alto	Ancho	Formato
10mm	15mm	Juntas

Material	ESP-EPDM 70° NEGRO
----------	--------------------

**10003855**

Alto	Ancho	Formato
13mm	20mm	Juntas

Material	ESP-EPDM 0.60°
----------	----------------

**A- 135**

Alto	Ancho	Formato
15,3mm	22mm	Juntas

Material	ESP-EPDM 0.60°
----------	----------------

**10003647**

Alto	Ancho	Formato
14,1mm	20,5mm	Juntas

Material	ESP-EPDM 0.65°
----------	----------------

**A- 136**

Alto	Ancho	Formato
15,3mm	22mm	Juntas

Material	ESP-EPDM 0.60°
----------	----------------

**10003368**

Alto	Ancho	Formato
9mm	15,5mm	Juntas

Material	ESP-EPDM 0.65°
----------	----------------

**10003886**

Alto	Ancho	Formato
12,7mm	12,2mm	Juntas

Material	EPDM CED. 0,65°
----------	-----------------

**10003790**

Alto	Ancho	Formato
6mm	4mm	Juntas

Material	EPDM 70° NEGRO
----------	----------------

**10003125**

Alto	Ancho	Formato
12mm	11mm	Juntas

Material	ESP-EPDM 0.55°
----------	----------------

**10000713**

Alto	Ancho	Formato
6mm	12mm	Juntas

Material	ESP-EPDM 0.55°
----------	----------------

**10000715**

Alto	Ancho	Formato
7mm	15mm	Juntas

Material	ESP-EPDM 0.55°
----------	----------------

**10001087**

Alto	Ancho	Formato
8mm	15mm	Juntas

Material	ESP-EPDM 0.55°
----------	----------------

**10003055**

Alto	Ancho	Inflado
32mm	35mm	38mm

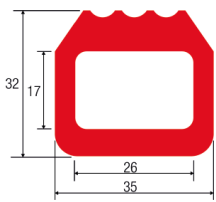

Presión min.	Presión rec.	Presión max.
10 PSI	15 PSI	18 PSI

**A- 115**

Alto	Ancho	Inflado
32mm	34,4mm	38mm

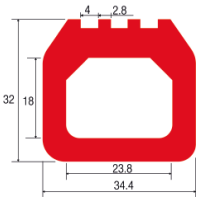

Presión min.	Presión rec.	Presión max.
10 PSI	15 PSI	18 PSI

**A- 116**

Alto	Ancho	Inflado
15mm	25,4mm	19mm

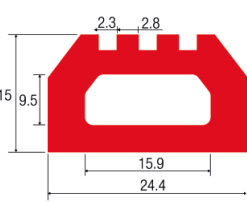

Presión min.	Presión rec.	Presión max.
10 PSI	15 PSI	20 PSI

**A- 117**

Alto	Ancho	Inflado
22,5mm	28,5mm	25,5mm

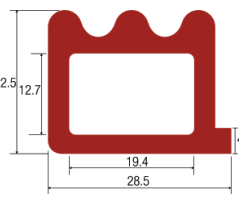

Presión min.	Presión rec.	Presión max.
8 PSI	10 PSI	12 PSI

**A- 118**

Alto	Ancho	Inflado
12,3mm	16,2mm	14mm

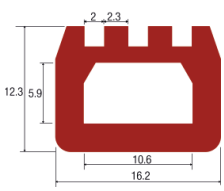

Presión min.	Presión rec.	Presión max.
10 PSI	15 PSI	20 PSI

**A-119**

Alto	Ancho	Inflado
11,5mm	15mm	13,5mm

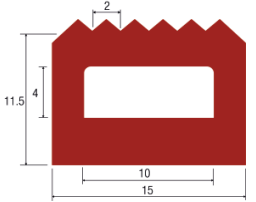

Presión min.	Presión rec.	Presión max.
10 PSI	15 PSI	20 PSI

**A-120**

Alto	Ancho	Inflado
23,3mm	50mm	41mm

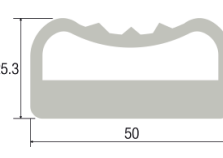

Presión min.	Presión rec.	Presión max.
8 PSI	10 PSI	13 PSI

**A-121**

Alto	Ancho	Inflado
28mm	40mm	34mm

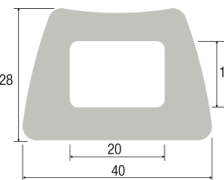

Presión min.	Presión rec.	Presión max.
20 PSI	25 PSI	35 PSI

**A- 122**

Alto	Ancho	Inflado
28mm	25,3mm	37mm

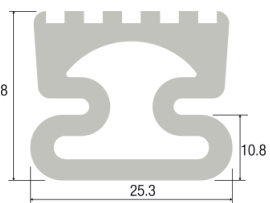

Presión min.	Presión rec.	Presión max.
8 PSI	10 PSI	15 PSI

**A-123**

Alto	Ancho	Inflado
7mm	16,9mm	11mm

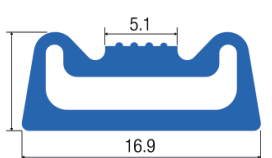

Presión min.	Presión rec.	Presión max.
8 PSI	12 PSI	16 PSI

**A-124**

Alto	Ancho	Inflado
24,4mm	25,3mm	37mm

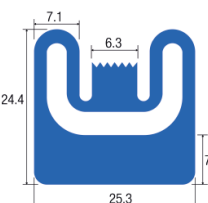

Presión min.	Presión rec.	Presión max.
15 PSI	20 PSI	25 PSI

**A-125**

Alto	Ancho	Inflado
11,7mm	20,5mm	18mm

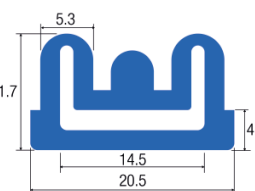

Presión min.	Presión rec.	Presión max.
10 PSI	15 PSI	20 PSI

**A-126**

Alto	Ancho	Inflado
10,1mm	14,5mm	15mm

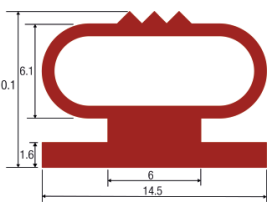

Presión min.	Presión rec.	Presión max.
8 PSI	10 PSI	15 PSI

**A-127**

Alto	Ancho	Inflado
23mm	51,4mm	42mm

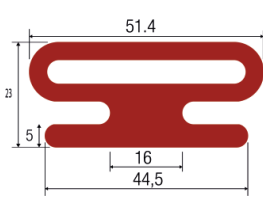

Presión min.	Presión rec.	Presión max.
15 PSI	20 PSI	25 PSI

**A-128**

Alto	Ancho	Inflado
13mm	14mm	23mm

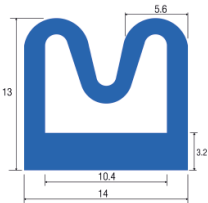

Presión min.	Presión rec.	Presión max.
10 PSI	20 PSI	25 PSI



**10001994**

Alto	Ancho	Formato
7mm	12mm	CR100m

Material EPDM 70° BLANCO

**10001784**

Alto	Ancho	Formato
7mm	12mm	CR75m

Material FKM 70° NEGRO

**10001536**

Alto	Ancho	Formato
7mm	12,2mm	R50m

Material NBR 70° NEGRO

**10001605**

Alto	Ancho	Formato
7mm	12,2mm	R50m

Material EPDM 70° NEGRO

**A- 114**

Alto	Ancho	Formato
7mm	12,2mm	R50m

Material SIL. 65° TRANS.

**10002748**

Alto	Ancho	Formato
9mm	23mm	CR50m

Material EPDM 70° NEGRO





**10003393**

Regata	Ancho	Formato
1,6mm	12,2mm	CR50m

Material	EPDM 70° - CEDULAR
----------	--------------------

**10003394**

Regata	Ancho	Formato
4mm	23mm	CR50m

Material	EPDM 70° - CEDULAR
----------	--------------------

**10003395**

Regata	Ancho	Formato
4,2mm	22mm	CR100m

Material	EPDM 70° - CEDULAR
----------	--------------------

**10003396**

Regata	Ancho	Formato
4,5mm	16,1mm	CR50m

Material	EPDM 70° - CEDULAR
----------	--------------------

**10003397**

Regata	Ancho	Formato
5,5mm	26mm	CR50m

Material	EPDM 70° - CEDULAR
----------	--------------------

**10003398**

Regata	Ancho	Formato
8,3mm	31mm	CR50m

Material	EPDM 70° - CEDULAR
----------	--------------------

**10003399**

Regata	Ancho	Formato
1,8mm	8,3mm	CR100m

Material	EPDM 70° - CEDULAR
----------	--------------------

**10003400**

Regata	Ancho	Formato
3,3mm	8mm	CR50m

Material	EPDM 70° - CEDULAR
----------	--------------------

**10003401**

Regata	Ancho	Formato
6mm	16mm	CR50m

Material	EPDM 70° - CEDULAR
----------	--------------------

**10003402**

Regata	Ancho	Formato
6,5mm	19,8mm	CR50m

Material	EPDM 70° - CEDULAR
----------	--------------------

**10003403**

Regata	Ancho	Formato
7mm	13mm	CR100m

Material	EPDM 70° - CEDULAR
----------	--------------------

**10003404**

Regata	Ancho	Formato
7mm	19mm	CR50m

Material	EPDM 70° - CEDULAR
----------	--------------------

**10003405**

Regata	Ancho	Formato
3,5mm	10mm	CR50m

Material	EPDM 70° - CEDULAR
----------	--------------------

**10003406**

Regata	Ancho	Formato
5mm	10mm	CR50m

Material	EPDM 70° - CEDULAR
----------	--------------------

**10003407**

Regata	Ancho	Formato
6mm	19,4mm	CR100m

Material	EPDM 70° - CEDULAR
----------	--------------------

**10000707**

Regata	Ancho	Formato
20mm	23mm	CR100m

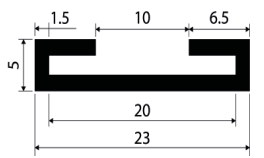

Material	EPDM 70° NEGRO
----------	----------------

**10000708**

Regata	Ancho	Formato
22mm	25mm	CR100m

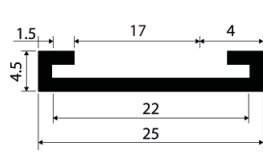

Material	EPDM 70° NEGRO
----------	----------------

**10001968**

Regata	Ancho	Formato
22,5mm	25mm	R100m

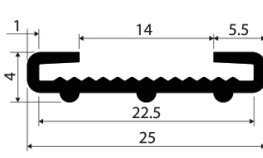

Material	EPDM 70° NEGRO
----------	----------------

**10001817**

Regata	Ancho	Formato
21,1mm	25,5mm	CR50m

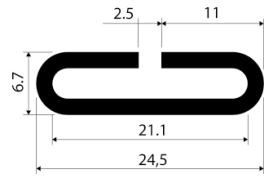

Material	EPDM 70° NEGRO
----------	----------------

**10000706**

Regata	Ancho	Formato
22mm	26mm	CR100m

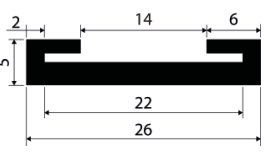

Material	EPDM 70° NEGRO
----------	----------------

**10003968**

Regata	Ancho	Formato
22,1mm	26,7mm	CR100m

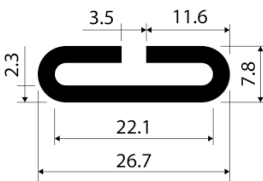

Material	EPDM 70° NEGRO
----------	----------------

**10002574**

Regata	Ancho	Formato
30mm	32,4mm	R100m

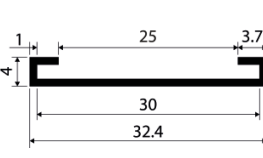

Material	EPDM 70° NEGRO
----------	----------------

**A- 169**

Regata	Ancho	Formato
29mm	33mm	CR50m

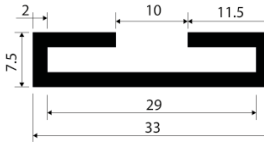

Material	EPDM 70° NEGRO
----------	----------------

**10001668**

Regata	Ancho	Formato
30,5mm	34,1mm	CR50m

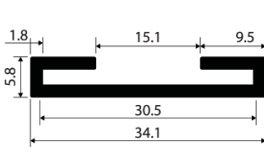

Material	EPDM 70° NEGRO
----------	----------------

**10002478**

Regata	Ancho	Formato
30,5mm	34,5mm	CR50m

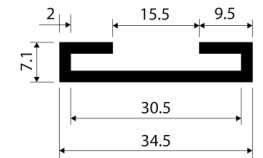

Material	EPDM 70° NEGRO
----------	----------------

**10002762**

Regata	Ancho	Formato
30mm	35mm	CR50m

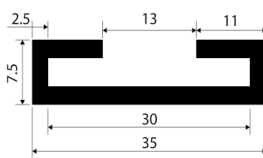

Material	EPDM 70° NEGRO
----------	----------------

**10002653**

Regata	Ancho	Formato
30mm	35,6mm	R50m

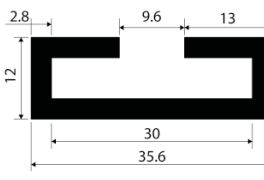

Material	EPDM 70° NEGRO
----------	----------------

**10000903**

Regata	Ancho	Formato
40,4mm	44mm	R50m

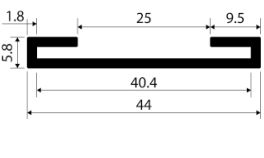

Material	EPDM 70° NEGRO
----------	----------------

**10001667**

Regata	Ancho	Formato
50mm	54mm	CR50m

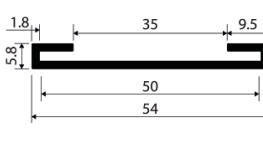

Material	EPDM 70° NEGRO
----------	----------------

**10003550**

Regata	Ancho	Formato
36,5mm	61mm	R25m

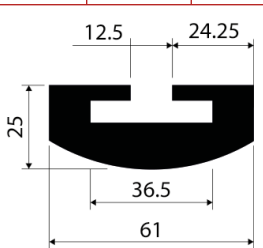

Material	EPDM 70° NEGRO
----------	----------------



**10003415**

Alto	Ancho	Formato
9mm	13mm	R100m

Material	EPDM 70° NEGRO
----------	----------------

**10003167**

Alto	Ancho	Formato
19mm	18mm	R50m

Material	EPDM IGN 70° NEGRO
----------	--------------------

**10001685**

Alto	Ancho	Formato
11,5mm	206mm	R50m

Material	EPDM 70° NEGRO
----------	----------------

**10002603**

Alto	Ancho	Formato
21mm	29mm	CR25m

Material	SILICONA 65° NEGRO
----------	--------------------

**10002469**

Alto	Ancho	Formato
10,16mm	30mm	R50m

Material	EPDM 70° NEGRO
----------	----------------

**10003012**

Alto	Ancho	Formato
18,5mm	29mm	R50m

Material	EPDM 70° NEGRO
----------	----------------

**10002986**

Alto	Ancho	Formato
12mm	30mm	CR50m

Material	EPDM 70° NEGRO
----------	----------------

**10003122**

Alto	Ancho	Formato
17,5mm	33,6mm	R50m

Material	EPDM 70° NEGRO
----------	----------------

**10001560**

Alto	Ancho	Formato
20mm	34mm	R50m

Material	EPDM 70° NEGRO
----------	----------------

**10002559**

Alto	Ancho	Formato
21mm	38mm	R50m

Material	EPDM 70° NEGRO
----------	----------------

**10000887**

Alto	Ancho	Formato
8,04mm	9,24mm	CR100m

Material	EPDM 70° NEGRO
----------	----------------

**10000964**

Alto	Ancho	Formato
15mm	20mm	CR50m

Material	EPDM 70° NEGRO
----------	----------------

**10003134**

Alto	Ancho	Formato
30mm	25mm	CR50m

Material	EPDM 70° NEGRO
----------	----------------

**10000946**

Alto	Ancho	Formato
20mm	29,5mm	CR25m

Material	EPDM 70° NEGRO
----------	----------------

**10000475**

Alto	Ancho	Formato
17,5mm	22,9mm	CR50m

Material	NBR 70° NEGRO
----------	---------------

**10000888**

Alto	Ancho	Formato
19,2mm	24mm	CR50m

Material	EPDM 70° NEGRO
----------	----------------



10003905		
Alto	Ancho	Formato
11mm	7,9mm	CR100m
Material	EPDM 70° NEGRO	

10002796		
Alto	Ancho	Formato
13,15mm	9,15mm	CR200m
Material	EPDM 70° NEGRO	

10002797		
Alto	Ancho	Formato
9,7mm	9,4mm	CR200m
Material	EPDM 70° NEGRO	

10003906		
Alto	Ancho	Formato
9,3mm	7,5mm	CR100m
Material	EPDM 70° NEGRO	

10003363		
Alto	Ancho	Formato
9.2mm	10.5mm	CR200m
Material	EPDM 70° NEGRO	

10003908		
Alto	Ancho	Formato
10,4mm	7,8mm	CR100m
Material	EPDM 70° NEGRO	

10003907		
Alto	Ancho	Formato
11,3mm	8,4mm	CR100m
Material	EPDM 70° NEGRO	

10003362		
Alto	Ancho	Formato
12,5mm	13mm	CR200m
Material	EPDM 70° NEGRO	

10003193		
Alto	Ancho	Formato
4mm	9mm	CR200m
Material	EPDM 70° NEGRO	

10002676		
Alto	Ancho	Formato
14mm	12mm	CR100m
Material	EPDM 70° NEGRO	

10003378		
Alto	Ancho	Formato
12,5mm	13mm	CR100m
Material	EPDM 50° NEGRO	

10001875		
Alto	Ancho	Formato
16,8mm	14mm	CR100m
Material	EPDM 70° NEGRO	

10002580		
Alto	Ancho	Formato
10,2mm	14,3mm	R100m
Material	EPDM 70° NEGRO	

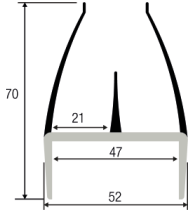
A- 100		
Alto	Ancho	Formato
70mm	52mm	TIRAS
		
Material	RÍGIDO-TPV 60°	

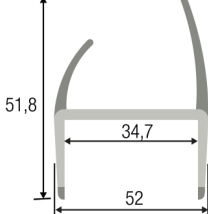
A- 101		
Alto	Ancho	Formato
51,8mm	52mm	TIRAS
		
Material	RÍGIDO-TPV 60°	

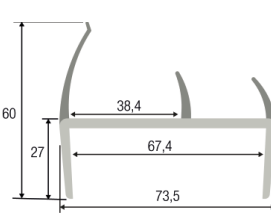
A- 102		
Alto	Ancho	Formato
60mm	73,5mm	TIRAS
		
Material	RÍGIDO-TPV 60°	

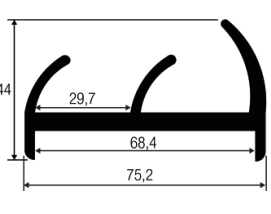
A- 103		
Alto	Ancho	Formato
44mm	75,2mm	TIRAS
		
Material	EPDM 70° NEGRO	

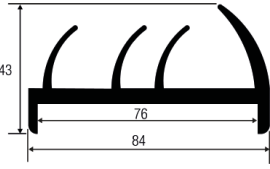
A- 104		
Alto	Ancho	Formato
43mm	84mm	TIRAS
		
Material	EPDM 70° NEGRO	

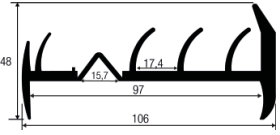
A- 105		
Alto	Ancho	Formato
48mm	106mm	TIRAS
		
Material	EPDM 70° NEGRO	



# EPDM / VMQ PERFILES PARA CONTAINER BASURA

**10002141**

Alto	Ancho	Formato
26mm	22mm	R25m

Material	EPDM 70° NEGRO
----------	----------------

**10003137**

Alto	Ancho	Formato
28,4mm	25,5mm	R30m

Material	EPDM 70° NEGRO
----------	----------------

**10002181**

Alto	Ancho	Formato
28,5mm	28mm	R30m

Material	EPDM 70° NEGRO
----------	----------------

**10000973**

Alto	Ancho	Formato
21,2mm	33,5mm	R25m

Material	EPDM 70° NEGRO
----------	----------------

**10002144**

Alto	Ancho	Formato
24mm	35mm	R25m

Material	EPDM 70° NEGRO
----------	----------------

**10000978**

Alto	Ancho	Formato
30mm	38mm	R25m

Material	EPDM 70° NEGRO
----------	----------------

**10003683**

Alto	Ancho	Formato
30mm	38mm	R25m

Material	SIL. 70° TRANS.
----------	-----------------

**10002126**

Alto	Ancho	Formato
30mm	38mm	R28m

Material	EPDM 70° NEGRO
----------	----------------

**10002125**

Alto	Ancho	Formato
30mm	38mm	R25m

Material	EPDM 50° NEGRO
----------	----------------

**10003643**

Alto	Ancho	Formato
38,9mm	48mm	R25m

Material	EPDM 70° NEGRO
----------	----------------



**A- 106**

Alto	Ancho	Formato
23,5mm	18mm	CR50m

Material	EPDM 70° - CEDULAR
----------	--------------------

**A- 107**

Alto	Ancho	Formato
8,6mm	7mm	CR100m

Material	EPDM 70° - CEDULAR
----------	--------------------

**A- 108**

Alto	Ancho	Formato
7,5mm	7,2mm	CR100m

Material	EPDM 70° - CEDULAR
----------	--------------------

**A- 109**

Alto	Ancho	Formato
8,7mm	12mm	CR100m

Material	EPDM 70° - CEDULAR
----------	--------------------

**100H1395**

Alto	Ancho	Formato
7mm	7mm	CR100m

Material	EPDM 70° - CEDULAR
----------	--------------------

**100H1394**

Alto	Ancho	Formato
18mm	15mm	CR100m

Material	EPDM 70° - CEDULAR
----------	--------------------



**10003358**

Alto	Ancho	Formato
45mm	45mm	R25m

Material EPDM 70° NEGRO

**10003357**

Alto	Ancho	Formato
70mm	80mm	TIRAS

Material EPDM 70° NEGRO

**10004044**

Alto	Ancho	Formato
49mm	38mm	TIRAS

Material EPDM 70° NEGRO

**10002348**

Alto	Ancho	Formato
33,5mm	32,4mm	R25m

Material EPDM 70° NEGRO

**10002408**

Alto	Ancho	Formato
38mm	37mm	R25m

Material EPDM 70° NEGRO

**10002095**

Alto	Ancho	Formato
37,6mm	39mm	TIRAS

Material EPDM 70° GRIS

**10001949**

Alto	Ancho	Formato
45mm	45mm	R25m

Material EPDM 70° NEGRO

**10004186**

Alto	Ancho	Formato
60mm	50mm	TIRAS

Material EPDM 70° NEGRO

**10003097**

Alto	Ancho	Formato
45mm	50mm	R25m

Material EPDM 70° NEGRO

**10003497**

Alto	Ancho	Formato
70mm	65mm	R25m

Material EPDM 70° NEGRO

**10003132**

Alto	Ancho	Formato
64mm	70mm	TIRAS

Material EPDM 70° NEGRO

**10003785**

Alto	Ancho	Formato
70mm	80mm	TIRAS

Material EPDM 70° NEGRO

**10003359**

Alto	Ancho	Formato
80mm	80mm	TIRAS

Material EPDM 70° NEGRO

**10003776**

Alto	Ancho	Formato
95mm	100mm	TIRAS

Material EPDM 70° NEGRO

**10004242**

Alto	Ancho	Formato
80mm	120mm	TIRAS

Material EPDM 70° NEGRO

**10004005**

Alto	Ancho	Formato
120mm	120mm	TIRAS

Material EPDM 70° NEGRO





**10002628**

Alto	Ancho	Formato
15mm	15,5mm	CR50m

Material EPDM 70° NEGRO

**10002629**

Alto	Ancho	Formato
15mm	15,5mm	CR50m

Material SIL. 70° ROJO VIVO

**10001632**

Alto	Ancho	Formato
14,5mm	16,5mm	CR50m

Material EPDM 70° NEGRO

**10001633**

Alto	Ancho	Formato
14,5mm	16,5mm	CR50m

Material SIL. 65° TRANS.

**10002626**

Alto	Ancho	Formato
13mm	17mm	CR50m

Material EPDM 70° NEGRO

**10002627**

Alto	Ancho	Formato
13mm	17mm	CR50m

Material SIL. 70° ROJO VIVO

**10001147**

Alto	Ancho	Formato
15mm	16mm	CR75m

Material EPDM 70° NEGRO

**10000196**

Alto	Ancho	Formato
17mm	18,5mm	CR50m

Material SIL. 65° GRIS

**10001143**

Alto	Ancho	Formato
17mm	18,5mm	CR50m

Material EPDM 70° NEGRO

**10001616**

Alto	Ancho	Formato
17mm	18,5mm	CR50m

Material SIL. 70° ROJO VIVO

**10003541**

Alto	Ancho	Formato
18mm	17,5mm	CR50m

Material EPDM CED. 0,65°

**10003547**

Alto	Ancho	Formato
15,5mm	15mm	R50m

Material EPDM CED. 0,65°

**10004333**

Alto	Ancho	Formato
15mm	10mm	CR100m

Material EPDM 70° NEGRO

**10002654**

Alto	Ancho	Formato
4,25mm	7,25mm	CR200m

Material EPDM 70° NEGRO

**10002380**

Alto	Ancho	Formato
10mm	10mm	CR100m

Material EPDM 70° NEGRO

**10000733**

Alto	Ancho	Formato
10mm	15mm	CR100m

Material EPDM 70° GRIS

**10002953**

Alto	Ancho	Formato
10mm	15mm	CR100m

Material EPDM 70° GRIS

**10003757**

Alto	Ancho	Formato
27mm	15,3mm	CR100m

Material SILICONA 70° NEGRO

**10003733**

Alto	Ancho	Formato
18mm	17,5mm	CR100

Material EPDM 70° NEGRO

**10003970**

Alto	Ancho	Formato
5mm	18mm	CR100m

Material EPDM 0,65° NEGRO

**10000201**

Alto	Ancho	Formato
20mm	20mm	CR100m

Material EPDM 70° NEGRO

**10000734**

Alto	Ancho	Formato
20mm	20mm	CR50m

Material EPDM 70° NEGRO

**10001241**

Alto	Ancho	Formato
22mm	22mm	CR100m

Material NEOPRENO 70° GRIS

**10002116**

Alto	Ancho	Formato
17,5mm	24,5mm	R50m

Material EPDM 70° NEGRO

**10003920**

Alto	Ancho	Formato
25mm	25mm	CR50m

Material EPDM 70° NEGRO

**10000735**

Alto	Ancho	Formato
30mm	30mm	CR50m

Material EPDM 70° NEGRO

**10002939**

Alto	Ancho	Formato
30mm	30mm	CR50m

Material EPDM 70° BLANCO

**10003522**

Alto	Ancho	Formato
35mm	35mm	R50m

Material EPDM 70° NEGRO

**10000898**

Alto	Ancho	Formato
13mm	37,14mm	R100m

Material EPDM 70° NEGRO

**10002117**

Alto	Ancho	Formato
40mm	40mm	R12m

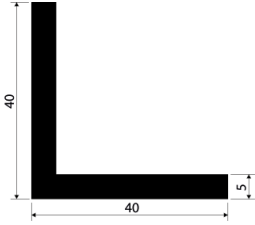

Material	EPDM 70° NEGRO
----------	----------------

**10004041**

Alto	Ancho	Formato
50mm	50mm	TIRAS

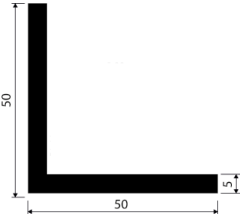

Material	EPDM 70° NEGRO
----------	----------------

**10002488**

Alto	Ancho	Formato
35mm	55mm	R25m

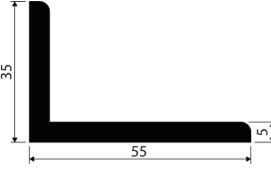

Material	EPDM 70° NEGRO
----------	----------------

**10001263**

Alto	Ancho	Formato
38mm	55mm	CR100m

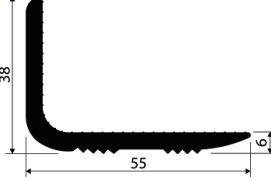

Material	EPDM 70° NEGRO
----------	----------------

**10002622**

Alto	Ancho	Formato
42mm	69mm	R50m

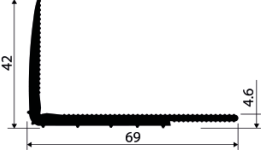

Material	EPDM 70° NEGRO
----------	----------------

**10003681**

Alto	Ancho	Formato
63mm	105mm	CR200m

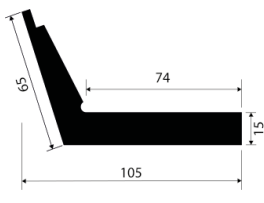

Material	EPDM 65° NEGRO
----------	----------------

**10002460**

Alto	Ancho	Formato
75mm	150mm	R10m



Material	EPDM 70° NEGRO
----------	----------------



**10000737**

Alto	Ancho	Formato
7mm	7mm	CR100m

Material	EPDM 70° NEGRO
----------	----------------

**10000540**

Alto	Ancho	Formato
10mm	8mm	CR100m

Material	EPDM 70° BLANCO
----------	-----------------

**10000505**

Alto	Ancho	Formato
13mm	8mm	CR100m

Material	EPDM 70° NEGRO
----------	----------------

**10002959 ADH**

Alto	Ancho	Formato
5mm	8,5mm	CR200m

Material	EPDM 48° GRIS
----------	---------------

**10000738**

Alto	Ancho	Formato
13mm	9,5mm	CR100m

Material	EPDM 70° NEGRO
----------	----------------

**10000549**

Alto	Ancho	Formato
15mm	13mm	CR50m

Material	EPDM 70° NEGRO
----------	----------------

**10000770**

Alto	Ancho	Formato
16mm	10mm	CR50m

Material	EPDM 70° NEGRO
----------	----------------

**10004330**

Alto	Ancho	Formato
5mm	10mm	CR200m

Material	EPDM 70° NEGRO
----------	----------------

**10001912**

Alto	Ancho	Formato
16mm	13mm	CR100m

Material	EPDM 70° NEGRO
----------	----------------

**10001960**

Alto	Ancho	Formato
25mm	10mm	CR50m

Material	EPDM 70° NEGRO
----------	----------------

**10000769**

Alto	Ancho	Formato
16mm	10,5mm	CR50m

Material	EPDM 70° NEGRO
----------	----------------

**10002475**

Alto	Ancho	Formato
12mm	12mm	CR50m

Material	SIL. 70° TRANS.
----------	-----------------

**10000740**

Alto	Ancho	Formato
14mm	12mm	CR100m

Material	EPDM 70° NEGRO
----------	----------------

**10002780**

Alto	Ancho	Formato
14mm	12mm	CR100m

Material	SILICONA 70° BLANCA
----------	---------------------

**10003589**

Alto	Ancho	Formato
14mm	12mm	CR50m

Material	EPDM 70° BLANCO
----------	-----------------

**10000704**

Alto	Ancho	Formato
7mm	13mm	CR100m

Material	EPDM 70° NEGRO
----------	----------------



**10002544 ADH**

Alto	Ancho	Formato
4,5mm	13mm	R100m

Material	EPDM 70° NEGRO
----------	----------------

**10002543**

Alto	Ancho	Formato
4,5mm	13mm	R100m

Material	EPDM 70° NEGRO
----------	----------------

**10000741**

Alto	Ancho	Formato
7mm	14mm	CR100m

Material	EPDM 70° NEGRO
----------	----------------

**10000743**

Alto	Ancho	Formato
8,5mm	14,5mm	CR50m

Material	EPDM 70° NEGRO
----------	----------------

**10000739**

Alto	Ancho	Formato
10mm	15mm	CR50m

Material	EPDM 70° NEGRO
----------	----------------

**10003058**

Alto	Ancho	Formato
12mm	15,5mm	CR200m

Material	EPDM 70° NEGRO
----------	----------------

**10000345**

Alto	Ancho	Formato
33,5mm	15,5mm	R50m

Material	EPDM 70° NEGRO
----------	----------------

**10002123**

Alto	Ancho	Formato
19mm	16mm	CR50m

Material	EPDM 70° NEGRO
----------	----------------

**10000866**

Alto	Ancho	Formato
16mm	17mm	R50m

Material	EPDM 70° NEGRO
----------	----------------

**10000744**

Alto	Ancho	Formato
11mm	17,5mm	CR50m

Material	EPDM 70° NEGRO
----------	----------------

**10001786**

Alto	Ancho	Formato
12mm	20mm	CR50m

Material	EPDM 70° NEGRO
----------	----------------

**10000742**

Alto	Ancho	Formato
10mm	20mm	CR50m

Material	EPDM 70° NEGRO
----------	----------------

**10000274**

Alto	Ancho	Formato
15mm	20mm	CR50m

Material	EPDM 70° NEGRO
----------	----------------

**10000896**

Alto	Ancho	Formato
20mm	20mm	R25m

Material	EPDM 70° BLANCO
----------	-----------------

**10002098**

Alto	Ancho	Formato
20mm	20mm	CR25m

Material	SIL. 65° ROJO VIVO
----------	--------------------

**10003133**

Alto	Ancho	Formato
50mm	25mm	R25m

Material	EPDM 70° NEGRO
----------	----------------



**10003804**

Alto	Ancho	Formato
11.5mm	26,5mm	R100m

Material	EPDM 70° NEGRO
----------	----------------

**10003422**

Alto	Ancho	Formato
40mm	37,5mm	R25m

Material	EPDM 70° NEGRO
----------	----------------

**10003234**

Alto	Ancho	Formato
20mm	40mm	R25m

Material	EPDM 70° NEGRO
----------	----------------

**10004309**

Alto	Ancho	Formato
29mm	40mm	R25m

Material	EPDM 65° NEGRO
----------	----------------

**10001642**

Alto	Ancho	Formato
24mm	42mm	CR25m

Material	EPDM 70° NEGRO
----------	----------------

**10002433**

Alto	Ancho	Formato
26mm	44mm	R30m

Material	EPDM 70° NEGRO
----------	----------------



**10003179**

Alto	Ancho	Formato
9mm	6mm	CR100m

Material	ESP-EPDM 0,65°
----------	----------------

**10001036**

Alto	Ancho	Formato
3,5mm	7mm	CR100m

Material	ESP-EPDM 0,85°
----------	----------------

**10002199**

Alto	Ancho	Formato
5mm	8mm	CR100m

Material	ESP-EPDM 0,85°
----------	----------------

**10000714**

Alto	Ancho	Formato
9mm	9mm	CR200m

Material	ESP-EPDM 0,60°
----------	----------------

**10000710**

Alto	Ancho	Formato
20mm	10mm	CR50m

Material	ESP-EPDM 0,60°
----------	----------------

**10003125**

Alto	Ancho	Formato
8mm	11mm	CR100m

Material	ESP-EPDM 0,55°
----------	----------------

**10003778**

Alto	Ancho	Formato
8mm	11mm	CR100m

Material	ESP-EPDM 0,60°
----------	----------------

**10000713**

Alto	Ancho	Formato
6mm	12mm	CR100m

Material	ESP-EPDM 0,55°
----------	----------------

**10003816**

Alto	Ancho	Formato
7mm	12mm	CR50

Material	ESP-EPDM 0,60°
----------	----------------

**10003498**

Alto	Ancho	Formato
10mm	12mm	CR50m

Material	ESP-EPDM 0,60°
----------	----------------

**10000716**

Alto	Ancho	Formato
17mm	12mm	CR50m

Material	ESP-EPDM 0,60°
----------	----------------

**10003273**

Alto	Ancho	Formato
8mm	13mm	CR100m

Material	ESP-EPDM 0,65°
----------	----------------

**10000712 ADH**

Alto	Ancho	Formato
7,9mm	14mm	CR100m

Material	ESP-EPDM 0,60°
----------	----------------

**10001252**

Alto	Ancho	Formato
7,9mm	14mm	CR100m

Material	ESP-EPDM 0,60°
----------	----------------

**10002048**

Alto	Ancho	Formato
29mm	14mm	CR50m

Material	ESP-EPDM 0,65°
----------	----------------

**10001496**

Alto	Ancho	Formato
7mm	15mm	CR100m

Material	ESP-EPDM 0,60°
----------	----------------



10000715		
Alto	Ancho	Formato
7mm	15mm	CR100m
Material	ESP-EPDM 0,55°	

10002173 ADH		
Alto	Ancho	Formato
7mm	15mm	CR100m
Material	ESP-EPDM 0,55°	

10001087		
Alto	Ancho	Formato
8mm	15mm	CR50m
Material	ESP-EPDM 0,55°	

10001253 ADH		
Alto	Ancho	Formato
8mm	15mm	CR100m
Material	ESP-EPDM 0,55°	

10003386		
Alto	Ancho	Formato
9mm	15mm	CR100m
Material	ESP-EPDM 0,65°	

10002441		
Alto	Ancho	Formato
11mm	17,5mm	CR50m
Material	ESP-EPDM 0,85°	

10002442 ADH		
Alto	Ancho	Formato
11mm	17,5mm	CR50m
Material	ESP-EPDM 0,85°	

10001114		
Alto	Ancho	Formato
8mm	18mm	CR100m
Material	ESP-EPDM 0,60°	

10001530		
Alto	Ancho	Formato
12mm	18mm	CR100m
Material	ESP-EPDM 0,55°	

10002547		
Alto	Ancho	Formato
12,5mm	18mm	CR50m
Material	ESP-EPDM 0,85°	

10002548 ADH		
Alto	Ancho	Formato
12,5mm	18mm	CR50m
Material	ESP-EPDM 0,85°	

10000711		
Alto	Ancho	Formato
9,5mm	19mm	CR50m
Material	ESP-EPDM 0,60°	

10003668		
Alto	Ancho	Formato
24mm	19mm	CR25m
Material	ESP-EPDM 0,65°	

10000939		
Alto	Ancho	Formato
12mm	20mm	CR50m
Material	ESP-EPDM 0,55°	

10002665		
Alto	Ancho	Formato
10mm	20mm	CR50m
Material	ESP-EPDM 0,55°	

10002341 ADH		
Alto	Ancho	Formato
13,5mm	20,5mm	CR50m
Material	ESP-EPDM 0,65°	





**10001025**

Alto	Ancho	Formato
13,5mm	20,5mm	CR50m

Material	ESP-EPDM 0,85°
----------	----------------

**10003662**

Alto	Ancho	Formato
23mm	22mm	CR25m

Material	ESP-EPDM 0,65°
----------	----------------

**10002495**

Alto	Ancho	Formato
20mm	30mm	CR25m

Material	ESP-EPDM 0,65°
----------	----------------

**10003435**

Alto	Ancho	Formato
30mm	30mm	R25m

Material	ESP-EPDM 0,65°
----------	----------------



COLECTOR A		
Alto	Ancho	Tubo ext.
91mm	203mm	10,6mm
Material	DELRIN BLANCO	

COLECTOR B		
Alto	Ancho	Tubo ext.
57mm	150mm	9,6mm
Material	DELRIN BLANCO	

10000928		
Alto	Ancho	Formato
10mm	90mm	R30m
Material	EPDM 70° NEGRO	

A- 112		
Alto	Ancho	Formato
12mm	91,2mm	R37m
Material	EPDM 70° NEGRO	

A- 113		
Alto	Ancho	Formato
12mm	121,6mm	R37m
Material	EPDM 70° NEGRO	

10002758		
Alto	Ancho	Tubo ext.
12mm	182,4mm	R37m
Material	EPDM 70° NEGRO	



**10000448**

Alto	Ancho	Formato
8,1mm	6mm	CR100m

Material	SILICONA 65° GRIS
----------	-------------------

**10000768**

Alto	Ancho	Formato
8mm	8mm	CR50m

Material	EPDM 70° NEGRO
----------	----------------

**10000767**

Alto	Ancho	Formato
7mm	10mm	CR100m

Material	EPDM 70° NEGRO
----------	----------------

**10000811**

Alto	Ancho	Formato
3,5mm	10,8mm	R100m

Material	EPDM 70° NEGRO
----------	----------------

**10000736**

Alto	Ancho	Formato
10mm	15mm	CR100m

Material	EPDM 70° NEGRO
----------	----------------

**10000397**

Alto	Ancho	Formato
10mm	15mm	CR100m

Material	SIL. 70° TRANS.
----------	-----------------

**10000683**

Alto	Ancho	Formato
8mm	16mm	CR100m

Material	EPDM 70° NEGRO
----------	----------------

**10004054**

Alto	Ancho	Formato
8mm	20mm	CR50m

Material	EPDM 70° NEGRO
----------	----------------

**10004349**

Alto	Ancho	Formato
22mm	24mm	R50m

Material	EPDM 70° NEGRO
----------	----------------

**10003285**

Alto	Ancho	Formato
12mm	25mm	CR50m

Material	EPDM 70° NEGRO
----------	----------------

**10003296**

Alto	Ancho	Formato
38mm	30mm	R25m

Material	EPDM 70° NEGRO
----------	----------------

**A-170**

Alto	Ancho	Formato
11mm	40mm	R25m

Material	EPDM 70° NEGRO
----------	----------------

**10003768**

Alto	Ancho	Formato
20mm	40mm	R25m

Material	EPDM 70° NEGRO
----------	----------------

**10002845**

Alto	Ancho	Formato
20mm	50mm	R25m

Material	EPDM IGN 70° NEGRO
----------	--------------------

**10004334**

Alto	Ancho	Formato
40mm	70mm	TIRAS

Material	EPDM 70° NEGRO
----------	----------------

**10003242**

Alto	Ancho	Formato
85mm	75mm	TIRAS

Material	EPDM 70° NEGRO
----------	----------------

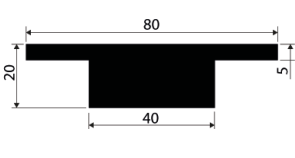

# EPDM / VMQ PERFILES FORMA T

10002846		
Alto	Ancho	Formato
20mm	80mm	R10m
		
Material	EPDM IGN 70° NEGRO	

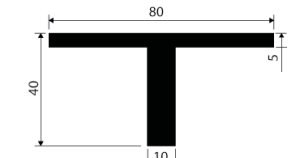
10002517		
Alto	Ancho	Formato
40mm	80mm	R25m
		
Material	EPDM 70° NEGRO	

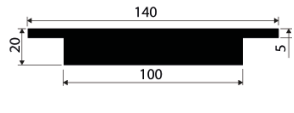
10002847		
Alto	Ancho	Formato
20mm	140mm	R5m
		
Material	EPDM IGN 70° NEGRO	



**10003338**

Alto	Ancho	Formato
8mm	9,5mm	CR100m

Material	EPDM 70° NEGRO
----------	----------------

**10002359**

Alto	Ancho	Formato
14mm	10mm	CR50m

Material	EPDM 70° NEGRO
----------	----------------

**10000763**

Alto	Ancho	Formato
5mm	10mm	CR100m

Material	EPDM 70° NEGRO
----------	----------------

**10000761**

Alto	Ancho	Formato
10mm	10mm	CR50m

Material	EPDM 70° NEGRO
----------	----------------

**10000874**

Alto	Ancho	Formato
7mm	11,5mm	CR100m

Material	EPDM 70° NEGRO
----------	----------------

**10000747**

Alto	Ancho	Formato
10mm	12mm	CR50m

Material	EPDM 70° NEGRO
----------	----------------

**10000745**

Alto	Ancho	Formato
14,5mm	12mm	CR50m

Material	EPDM 70° NEGRO
----------	----------------

**10000899**

Alto	Ancho	Formato
14,5mm	12mm	CR50m

Material	NBR 70° NEGRO
----------	---------------

**10001818**

Alto	Ancho	Formato
9mm	12mm	CR100m

Material	NBR 70° NEGRO
----------	---------------

**10002215**

Alto	Ancho	Formato
8,5mm	12,5mm	CR100m

Material	SIL. 65° TRANS.
----------	-----------------

**10000326**

Alto	Ancho	Formato
11mm	12,4mm	CR100m

Material	EPDM 70° NEGRO
----------	----------------

**10002097**

Alto	Ancho	Formato
10mm	13mm	CR100m

Material	EPDM 70° BLANCO
----------	-----------------

**10002781**

Alto	Ancho	Formato
10mm	14mm	CR100m

Material	SIL. 65° ROJO TEJA
----------	--------------------

**10000106**

Alto	Ancho	Formato
14mm	15mm	CR50m

Material	EPDM 70° NEGRO
----------	----------------

**10000762**

Alto	Ancho	Formato
10mm	15mm	CR50m

Material	EPDM 70° NEGRO
----------	----------------

**10000746**

Alto	Ancho	Formato
15mm	15mm	CR50m

Material	EPDM 70° NEGRO
----------	----------------



**100H1545**

Alto	Ancho	Formato
14mm	16mm	CR25m

Material	EPDM 70° NEGRO
----------	----------------

**10000765**

Alto	Ancho	Formato
15mm	17mm	CR25m

Material	EPDM 70° NEGRO
----------	----------------

**10000764**

Alto	Ancho	Formato
10mm	20mm	CR50m

Material	EPDM 70° NEGRO
----------	----------------

**10000766**

Alto	Ancho	Formato
10mm	20mm	CR50m

Material	EPDM 70° NEGRO
----------	----------------

**10000985**

Alto	Ancho	Formato
16mm	20mm	R50m

Material	EPDM 70° NEGRO
----------	----------------

**10000373**

Alto	Ancho	Formato
18mm	20mm	CR25m

Material	EPDM 70° NEGRO
----------	----------------

**10001826**

Alto	Ancho	Formato
13,5mm	25mm	CR50m

Material	EPDM 70° NEGRO
----------	----------------

**10001799**

Alto	Ancho	Formato
15mm	25mm	CR50m

Material	EPDM 70° NEGRO
----------	----------------

**10000510**

Alto	Ancho	Formato
21,5mm	35,5mm	R25m

Material	EPDM 70° NEGRO
----------	----------------

**10001145**

Alto	Ancho	Formato
24mm	40mm	R20m

Material	EPDM 70° NEGRO
----------	----------------

**10004256**

Alto	Ancho	Formato
30mm	50mm	R25m

Material	EPDM 70° NEGRO
----------	----------------

**10001242**

Alto	Ancho	Formato
35mm	50mm	R20m

Material	EPDM 70° NEGRO
----------	----------------

**10004210**

Alto	Ancho	Formato
35mm	50mm	TIRAS

Material	EPDM 60° NEGRO
----------	----------------

**10002771**

Alto	Ancho	Formato
22mm	100mm	R10m

Material	EPDM 70° NEGRO
----------	----------------



**10003327**

Regata	Alto	Formato
0,9mm	8mm	R750m

Material	POLIETILENO 90°
----------	-----------------

**10002445**

Regata	Alto	Formato
1mm	5,4mm	CR50m

Material	EPDM 70° NEGRO
----------	----------------

**10003505**

Regata	Alto	Formato
1mm	6mm	CR100m

Material	EPDM 70° NEGRO
----------	----------------

**10000922**

Regata	Alto	Formato
1mm	8mm	CR100m

Material	SIL. 70° TRANS.
----------	-----------------

**10002189**

Regata	Alto	Formato
1mm	8mm	CR200m

Material	EPDM 70° NEGRO
----------	----------------

**10000229**

Regata	Alto	Formato
1mm	8,5mm	CR100m

Material	EPDM 70° NEGRO
----------	----------------

**10000966**

Regata	Alto	Formato
1mm	9mm	CR100m

Material	SIL. 65° TRANS.
----------	-----------------

**10000755**

Regata	Alto	Formato
1mm	10mm	CR100m

Material	EPDM 70° NEGRO
----------	----------------

**10000756**

Regata	Alto	Formato
1mm	12mm	CR100m

Material	EPDM 70° NEGRO
----------	----------------

**10001528**

Regata	Alto	Formato
1mm	15mm	CR100m

Material	EPDM 70° NEGRO
----------	----------------

**10002795**

Regata	Alto	Formato
1mm	18,1mm	CR100m

Material	EPDM 70° NEGRO
----------	----------------

**10001590**

Regata	Alto	Formato
1,25mm	6,5mm	CR200m

Material	EPDM 70° NEGRO
----------	----------------

**10003899**

Regata	Alto	Formato
1,3mm	11mm	CR200m

Material	EPDM 70° NEGRO
----------	----------------

**10001216**

Regata	Alto	Formato
1,3mm	16,5mm	CR100m

Material	EPDM 70° NEGRO
----------	----------------

**10000155**

Regata	Alto	Formato
1,5mm	6mm	CR100m

Material	EPDM 70° NEGRO
----------	----------------

**10000248**

Regata	Alto	Formato
1,5mm	6mm	CR200m

Material	NBR 70° NEGRO
----------	---------------



**10001194**

Regata	Alto	Formato
1,5mm	8,5mm	CR200m

Material	EPDM 70° NEGRO
----------	----------------

**10000758**

Regata	Alto	Formato
1,5mm	9mm	CR100m

Material	EPDM 70° NEGRO
----------	----------------

**10004326**

Regata	Alto	Formato
1,5mm	9,5mm	CR250m

Material	EPDM IGN 70° NEGRO
----------	--------------------

**10003677**

Regata	Alto	Formato
1,5mm	10mm	CR200m

Material	EPDM 70° NEGRO
----------	----------------

**10001033**

Regata	Alto	Formato
1,5mm	11mm	CR100m

Material	EPDM 70° NEGRO
----------	----------------

**10000997**

Regata	Alto	Formato
1,5mm	11mm	R100m

Material	EPDM 70° NEGRO
----------	----------------

**10002042**

Regata	Alto	Formato
1,5mm	12mm	CR100m

Material	EPDM 70° NEGRO
----------	----------------

**10000487**

Regata	Alto	Formato
1,5mm	12,5mm	CR100m

Material	EPDM 70° NEGRO
----------	----------------

**10001966**

Regata	Alto	Formato
1,5mm	12,5mm	CR100m

Material	EPDM 70° BLANCO
----------	-----------------

**1003904**

Regata	Alto	Formato
1,5mm	13mm	CR100m

Material	EPDM 70° NEGRO
----------	----------------

**10001012**

Regata	Alto	Formato
1,5mm	13,5mm	CR100m

Material	SILICONA 65° TRANS.
----------	---------------------

**10000139**

Regata	Alto	Formato
1,5mm	13,5mm	CR100m

Material	EPDM 70° NEGRO
----------	----------------

**10002043**

Regata	Alto	Formato
1,5mm	15mm	CR100m

Material	EPDM 70° NEGRO
----------	----------------

**1000666**

Regata	Alto	Formato
1,5mm	13,5mm	CR100m

Material	SILICONA 65° NEGRA
----------	--------------------

**10000810**

Regata	Alto	Formato
1,55mm	7mm	CR100m

Material	EPDM 70° NEGRO
----------	----------------

**10003900**

Regata	Alto	Formato
1,55mm	17,5mm	CR100m

Material	EPDM 70° NEGRO
----------	----------------





**10004178**

Regata	Alto	Formato
1,6mm	7,5mm	CR250m

Material	SILICONA 30° TRANS.
----------	---------------------

**10003207**

Regata	Alto	Formato
1,7mm	6mm	CR200m

Material	NEOPRENO 70° NEGRO
----------	--------------------

**1000691**

Regata	Alto	Formato
2mm	5mm	CR250m

Material	EPDM 70° NEGRO
----------	----------------

**10002836**

Regata	Alto	Formato
2mm	6mm	CR250m

Material	EPDM 70° NEGRO
----------	----------------

**10001951**

Regata	Alto	Formato
2mm	7,5mm	CR100m

Material	EPDM 70° NEGRO
----------	----------------

**10001200**

Regata	Alto	Formato
2mm	8mm	CR100m

Material	EPDM 70° NEGRO
----------	----------------

**10003593**

Regata	Alto	Formato
2mm	8mm	CR200m

Material	EPDM IGN 70° NEGRO
----------	--------------------

**10001745**

Regata	Alto	Formato
2mm	9mm	CR100m

Material	EPDM 70° NEGRO
----------	----------------

**10003090**

Regata	Alto	Formato
2mm	9mm	TIRAS

Material	EPDM 70° NEGRO
----------	----------------

**10003800**

Regata	Alto	Formato
2mm	9mm	CR200m

Material	EPDM 70° NEGRO
----------	----------------

**10000988**

Regata	Alto	Formato
2mm	10mm	R100m

Material	EPDM 70° NEGRO
----------	----------------

**10003903**

Regata	Alto	Formato
2mm	11mm	CR200m

Material	EPDM 70° NEGRO
----------	----------------

**10002888**

Regata	Alto	Formato
2mm	12mm	CR100m

Material	EPDM IGN 70° NEGRO
----------	--------------------

**10000759**

Regata	Alto	Formato
2mm	12mm	CR100m

Material	EPDM 70° NEGRO
----------	----------------

**10000760**

Regata	Alto	Formato
2mm	12mm	CR50m

Material	EPDM 70° NEGRO
----------	----------------

**10000925**

Regata	Alto	Formato
2mm	12mm	CR100m

Material	EPDM 70° NEGRO
----------	----------------



**10001007**

Regata	Alto	Formato
2mm	12mm	R100m

Material	EPDM 70° NEGRO
----------	----------------

**10001497**

Regata	Alto	Formato
2mm	12mm	CR100m

Material	EPDM 70° NEGRO
----------	----------------

**10000417**

Regata	Alto	Formato
2mm	12,7mm	CR100m

Material	EPDM 70° NEGRO
----------	----------------

**10000613**

Regata	Alto	Formato
2mm	14mm	CR100m

Material	EPDM 70° NEGRO
----------	----------------

**10001089**

Regata	Alto	Formato
2mm	15mm	R100m

Material	EPDM 70° NEGRO
----------	----------------

**10000924**

Regata	Alto	Formato
2mm	15mm	CR100m

Material	EPDM 70° NEGRO
----------	----------------

**10003765**

Regata	Alto	Formato
2mm	16,2mm	CR100m

Material	EPDM 70° NEGRO
----------	----------------

**10000269**

Regata	Alto	Formato
2mm	16,2mm	CR100m

Material	EPDM 70° BLANCO
----------	-----------------

**10001141**

Regata	Alto	Formato
2mm	17,2mm	CR100m

Material	EPDM 70° NEGRO
----------	----------------

**10000075**

Regata	Alto	Formato
2,4mm	12mm	CR100m

Material	SILICONA 65° TRANS.
----------	---------------------

**10001677**

Regata	Alto	Formato
2,5mm	8mm	CR100m

Material	NBR 70° NEGRO
----------	---------------

**10002941**

Regata	Alto	Formato
2,5mm	8,5mm	CR100m

Material	EPDM 70° NEGRO
----------	----------------

**10001262**

Regata	Alto	Formato
2,5mm	10mm	CR100m

Material	EPDM 70° NEGRO
----------	----------------

**10001026**

Regata	Alto	Formato
2,5mm	10,9mm	CR100m

Material	EPDM 70° NEGRO
----------	----------------

**10001027**

Regata	Alto	Formato
2,5mm	13mm	CR100m

Material	EPDM 70° NEGRO
----------	----------------

**10000616**

Regata	Alto	Formato
2,5mm	16mm	CR100m

Material	EPDM 70° NEGRO
----------	----------------



**10002102**

Regata	Alto	Formato
2,6mm	19,9mm	CR120m

Material	EPDM 70° NEGRO
----------	----------------

**10002334**

Regata	Alto	Formato
2,8mm	14mm	CR100m

Material	EPDM 70° NEGRO
----------	----------------

**10004191**

Regata	Alto	Formato
2,8mm	15mm	CR100m

Material	SILICONA TRANS 50°
----------	--------------------

**10003243**

Regata	Alto	Formato
3mm	5mm	CR200m

Material	EPDM 70° NEGRO
----------	----------------

**10004298**

Regata	Alto	Formato
3mm	8mm	CR250m

Material	EPDM IGN 70° NEGRO
----------	--------------------

**10000917**

Regata	Alto	Formato
3mm	9mm	R500m

Material	EPDM 70° NEGRO
----------	----------------

**10004213**

Regata	Alto	Formato
3mm	9mm	CR100m

Material	EPDM 70° NEGRO
----------	----------------

**10000846**

Regata	Alto	Formato
3mm	9,2mm	CR50m

Material	EPDM 70° NEGRO
----------	----------------

**10001110**

Regata	Alto	Formato
3mm	10mm	CR100m

Material	EPDM 70° NEGRO
----------	----------------

**10004284**

Regata	Alto	Formato
3mm	10,4mm	CR100m

Material	EPDM IGN 70° NEGRO
----------	--------------------

**10002643**

Regata	Alto	Formato
3mm	12mm	CR100m

Material	EPDM 70° NEGRO
----------	----------------

**10003163**

Regata	Alto	Formato
3mm	13,5mm	CR100m

Material	EPDM 70° NEGRO
----------	----------------

**10003904**

Regata	Alto	Formato
3mm	13mm	CR100m

Material	EPDM 70° NEGRO
----------	----------------

**10000538**

Regata	Alto	Formato
3mm	15mm	CR100m

Material	EPDM 70° NEGRO
----------	----------------

**10000617**

Regata	Alto	Formato
3mm	16mm	CR50m

Material	EPDM 70° NEGRO
----------	----------------

**10004286**

Regata	Alto	Formato
3mm	18mm	CR75m

Material	EPDM IGN 70° NEGRO
----------	--------------------



**10002716**

Regata	Alto	Formato
3mm	20mm	CR25m

Material	EPDM 70° NEGRO
----------	----------------

**10001519**

Regata	Alto	Formato
3mm	20mm	CR50m

Material	EPDM 70° NEGRO
----------	----------------

**10001964**

Regata	Alto	Formato
3mm	20mm	CR25m

Material	EPDM 70° GRIS
----------	---------------

**10003423**

Regata	Alto	Formato
3mm	24,5mm	CR50m

Material	EPDM 70° NEGRO
----------	----------------

**10001125**

Regata	Alto	Formato
3mm	25mm	R25m

Material	EPDM 70° NEGRO
----------	----------------

**10003972**

Regata	Alto	Formato
3mm	25mm	CR50m

Material	EPDM 70° NEGRO
----------	----------------

**10003033**

Regata	Alto	Formato
3mm	32mm	CR50m

Material	EPDM 70° NEGRO
----------	----------------

**10001644**

Regata	Alto	Formato
3,5mm	19mm	R25m

Material	EPDM 70° NEGRO
----------	----------------

**10000856**

Regata	Alto	Formato
3,7mm	13,5mm	CR100m

Material	EPDM 70° NEGRO
----------	----------------

**10003831**

Regata	Alto	Formato
4mm	9mm	R90m

Material	EPDM 70° NEGRO
----------	----------------

**10003517**

Regata	Alto	Formato
4mm	10mm	CR200m

Material	EPDM 70° NEGRO
----------	----------------

**10002756**

Regata	Alto	Formato
4mm	11mm	CR100m

Material	EPDM 70° NEGRO
----------	----------------

**10000079**

Regata	Alto	Formato
4mm	12mm	CR100m

Material	EPDM 70° NEGRO
----------	----------------

**10000748**

Regata	Alto	Formato
4mm	12mm	CR100m

Material	EPDM 70° NEGRO
----------	----------------

**10000889**

Regata	Alto	Formato
4mm	12mm	CR100m

Material	EPDM 70° NEGRO
----------	----------------

**10001233**

Regata	Alto	Formato
4mm	12mm	CR50m

Material	EPDM 70° NEGRO
----------	----------------



**10002320**

Regata	Alto	Formato
4mm	12mm	CR100m

Material	EPDM 70° NEGRO
----------	----------------

**10003920**

Regata	Alto	Formato
4mm	12mm	CR50m

Material	EPDM 70° NEGRO
----------	----------------

**10001524**

Regata	Alto	Formato
4mm	15mm	CR100m

Material	EPDM 70° NEGRO
----------	----------------

**10001517**

Regata	Alto	Formato
4mm	15mm	CR100m

Material	EPDM 70° NEGRO
----------	----------------

**10003901**

Regata	Alto	Formato
4mm	15mm	CR100m

Material	EPDM 70° NEGRO
----------	----------------

**10003314**

Regata	Alto	Formato
4mm	20mm	CR50m

Material	EPDM 70° NEGRO
----------	----------------

**10002534**

Regata	Alto	Formato
4mm	26mm	R25m

Material	EPDM 70° NEGRO
----------	----------------

**10002575**

Regata	Alto	Formato
4mm	30mm	CR25m

Material	EPDM 70° NEGRO
----------	----------------

**10002864**

Regata	Alto	Formato
4mm	38mm	CR50m

Material	EPDM IGN 70° NEGRO
----------	--------------------

**10000945**

Regata	Alto	Formato
4,5mm	8mm	CR100m

Material	EPDM 70° NEGRO
----------	----------------

**10000961**

Regata	Alto	Formato
4,5mm	17,5mm	CR50m

Material	NBR 70° NEGRO
----------	---------------

**10002502**

Regata	Alto	Formato
4,8mm	19,7mm	CR50m

Material	EPDM 70° NEGRO
----------	----------------

**10003460**

Regata	Alto	Formato
5mm	6,1mm	CR200m

Material	EPDM 70° NEGRO
----------	----------------

**10004069**

Regata	Alto	Formato
5mm	11mm	CR100m

Material	EPDM 70° NEGRO
----------	----------------

**10003192**

Regata	Alto	Formato
5mm	12,4mm	CR100m

Material	EPDM 70° NEGRO
----------	----------------

**10000614**

Regata	Alto	Formato
5mm	13mm	CR100m

Material	EPDM 70° NEGRO
----------	----------------



**10003126**

Regata	Alto	Formato
5mm	14,5mm	CR100m

Material	EPDM 70° NEGRO
----------	----------------

**10004287**

Regata	Alto	Formato
5mm	16mm	CR75m

Material	EPDM IGN 70° NEGRO
----------	--------------------

**10002014**

Regata	Alto	Formato
5mm	18mm	CR50m

Material	EPDM 70° NEGRO
----------	----------------

**10004176**

Regata	Alto	Formato
5mm	18mm	CR50m

Material	EPDM 70° NEGRO
----------	----------------

**10001500**

Regata	Alto	Formato
5mm	19mm	CR50m

Material	EPDM 70° NEGRO
----------	----------------

**10001518**

Regata	Alto	Formato
5mm	20mm	CR50m

Material	EPDM 70° NEGRO
----------	----------------

**10000615**

Regata	Alto	Formato
5mm	22mm	CR100m

Material	EPDM 70° NEGRO
----------	----------------

**10004308**

Regata	Alto	Formato
5mm	23mm	CR30m

Material	EPDM 70° NEGRO
----------	----------------

**10001086**

Regata	Alto	Formato
5mm	25mm	CR25m

Material	EPDM 50° NEGRO
----------	----------------

**10001106**

Regata	Alto	Formato
5mm	25mm	CR25m

Material	EPDM 70° NEGRO
----------	----------------

**10003529**

Regata	Alto	Formato
5mm	43mm	CR100m

Material	EPDM 70° NEGRO
----------	----------------

**10003529**

Regata	Alto	Formato
5,1mm	30mm	R50m

Material	EPDM 70° NEGRO
----------	----------------

**10001751**

Regata	Alto	Formato
6mm	11mm	CR100m

Material	EPDM 70° NEGRO
----------	----------------

**10002750**

Regata	Alto	Formato
6mm	13mm	CR100m

Material	EPDM 70° NEGRO
----------	----------------

**10000785**

Regata	Alto	Formato
6mm	15mm	CR50m

Material	EPDM 70° NEGRO
----------	----------------

**10000140**

Regata	Alto	Formato
6mm	15mm	CR50m

Material	EPDM 70° NEGRO
----------	----------------



**10003050**

Regata	Alto	Formato
6mm	15mm	CR50m

Material	SILICONA 70° TRANS.
----------	---------------------

**10000749**

Regata	Alto	Formato
6mm	18mm	CR50m

Material	EPDM 70° NEGRO
----------	----------------

**10000875**

Regata	Alto	Formato
6mm	20,5mm	CR100m

Material	EPDM 70° NEGRO
----------	----------------

**10003315**

Regata	Ancho	Formato
6mm	25mm	CR100m

Material	SILICONA 70° TRANS.
----------	---------------------

**10001085**

Regata	Alto	Formato
6mm	33,5mm	CR25m

Material	EPDM 70° NEGRO
----------	----------------

**10003304**

Regata	Alto	Formato
6mm	38mm	R25m

Material	EPDM 70° NEGRO
----------	----------------

**100H1498**

Regata	Alto	Formato
6mm	46mm	CR100m

Material	SIL. HT 70° NEGRO
----------	-------------------

**10000418**

Regata	Alto	Formato
7mm	15mm	CR50m

Material	EPDM 70° NEGRO
----------	----------------

**10000750**

Regata	Ancho	Formato
7mm	15mm	CR50m

Material	EPDM 70° NEGRO
----------	----------------

**10003902**

Regata	Alto	Formato
7mm	15,5mm	CR100m

Material	EPDM 70° NEGRO
----------	----------------

**10003830**

Regata	Alto	Formato
7mm	16,5mm	R90m

Material	EPDM 70° NEGRO
----------	----------------

**10002714**

Regata	Alto	Formato
7mm	20mm	R50m

Material	EPDM 70° NEGRO
----------	----------------

**10001249**

Regata	Alto	Formato
7mm	30mm	CR25m

Material	EPDM 70° NEGRO
----------	----------------

**10002413**

Regata	Ancho	Formato
7,5mm	9,7mm	CR250m

Material	EPDM 70° NEGRO
----------	----------------

**10000619**

Regata	Alto	Formato
7,8mm	17mm	CR100m

Material	EPDM 70° NEGRO
----------	----------------

**10003255**

Regata	Alto	Formato
8mm	12mm	CR100m

Material	EPDM 70° NEGRO
----------	----------------



**10002106**

Regata	Alto	Formato
8mm	13,5mm	CR100m

Material	EPDM 70° NEGRO
----------	----------------

**10000689**

Regata	Ancho	Formato
8mm	13mm	CR100m

Material	EPDM 70° NEGRO
----------	----------------

**10002657**

Regata	Alto	Formato
8mm	14mm	CR100m

Material	EPDM 70° NEGRO
----------	----------------

**10003324**

Regata	Alto	Formato
8mm	14,5mm	CR100m

Material	EPDM 70° NEGRO
----------	----------------

**10003584**

Regata	Alto	Formato
8mm	15mm	CR100m

Material	EPDM 70° NEGRO
----------	----------------

**10000753**

Regata	Alto	Formato
8mm	16mm	CR50m

Material	EPDM 70° NEGRO
----------	----------------

**10002999**

Regata	Alto	Formato
8mm	16mm	CR50m

Material	SILICONA 70° GRIS
----------	-------------------

**10002337**

Regata	Alto	Formato
8mm	18mm	CR50m

Material	EPDM 70° NEGRO
----------	----------------

**10000751**

Regata	Alto	Formato
8mm	21mm	CR50m

Material	EPDM 70° NEGRO
----------	----------------

**10004214**

Regata	Alto	Formato
8mm	22mm	R50m

Material	EPDM 70° NEGRO
----------	----------------

**10001659**

Regata	Alto	Formato
8mm	25mm	CR25m

Material	EPDM 70° NEGRO
----------	----------------

**100H1495**

Regata	Alto	Formato
9mm	13mm	CR50m

Material	EPDM 70° NEGRO
----------	----------------

**10000752**

Regata	Alto	Formato
9mm	15mm	CR50m

Material	EPDM 70° NEGRO
----------	----------------

**10001665**

Regata	Alto	Formato
9mm	25mm	CR25m

Material	EPDM 70° NEGRO
----------	----------------

**10003762**

Regata	Alto	Formato
9mm	28mm	CR50m

Material	NEOPRENO 70° NEGRO
----------	--------------------

**10003971**

Regata	Alto	Formato
9mm	28mm	R25m

Material	EPDM 70° NEGRO
----------	----------------





10004036		
Regata	Alto	Formato
9,5mm	46mm	R25m
Material	EPDM 70° NEGRO	

1000		
Regata	Alto	Formato
10mm	35mm	TIRAS
Material	EPDM 70° NEGRO	

10003414		
Regata	Alto	Formato
10mm	12mm	CR100m
Material	EPDM 70° NEGRO	

10000200		
Regata	Alto	Formato
10mm	15mm	CR100m
Material	EPDM 70° NEGRO	

10003298		
Regata	Alto	Formato
10mm	15mm	CR100m
Material	EPDM 70° NEGRO	

10001664		
Regata	Alto	Formato
10mm	25mm	CR25m
Material	EPDM 70° NEGRO	

10003131		
Regata	Alto	Formato
10mm	25,8mm	CR50m
Material	EPDM 70° NEGRO	

10002693		
Regata	Alto	Formato
10mm	27mm	R25m
Material	EPDM 70° NEGRO	

10004056		
Regata	Alto	Formato
10mm	31mm	R25m
Material	EPDM 70° NEGRO	

10001788		
Regata	Alto	Formato
10mm	49mm	CR100m
Material	EPDM 70° NEGRO	

10001248		
Regata	Alto	Formato
10,5mm	50mm	R25m
Material	EPDM 70° NEGRO	

10002576		
Regata	Alto	Formato
11mm	55mm	R25m
Material	EPDM 70° NEGRO	

10001501		
Regata	Alto	Formato
12mm	17mm	CR50m
Material	EPDM 70° NEGRO	

10002494		
Regata	Alto	Formato
12mm	18mm	CR50m
Material	EPDM 70° NEGRO	

10000754		
Regata	Alto	Formato
12mm	20mm	CR50m
Material	EPDM 70° NEGRO	

10003225		
Regata	Alto	Formato
12mm	29mm	CR50m
Material	EPDM 70° NEGRO	



**10002841**

Regata	Alto	Formato
12mm	35mm	R25m

Material	EPDM 70° NEGRO
----------	----------------

**10002757**

Regata	Alto	Formato
12mm	35mm	R50m

Material	EPDM 70° NEGRO
----------	----------------

**10000442**

Regata	Alto	Formato
12mm	35,5mm	CR25m

Material	EPDM 70° NEGRO
----------	----------------

**10003540**

Regata	Alto	Formato
12,2mm	43,3mm	CR100m

Material	EPDM 70° NEGRO
----------	----------------

**10003387**

Regata	Alto	Formato
12,5mm	50mm	R25m

Material	EPDM 70° NEGRO
----------	----------------

**10003710**

Regata	Alto	Formato
13mm	26mm	R25m

Material	EPDM 70° NEGRO
----------	----------------

**10001672**

Regata	Ancho	Formato
13,5mm	29,5mm	R25m

Material	EPDM 70° NEGRO
----------	----------------

**100H1313**

Regata	Ancho	Formato
14mm	27mm	R25m

Material	EPDM 60° NEGRO
----------	----------------

**10002332**

Regata	Alto	Formato
14,5mm	36,8mm	R25m

Material	EPDM 70° NEGRO
----------	----------------

**10003875**

Regata	Alto	Formato
15mm	18mm	R25

Material	NBR 70° NEGRO
----------	---------------

**10003565**

Regata	Alto	Formato
15mm	32mm	R25m

Material	EPDM 70° NEGRO
----------	----------------

**10002721**

Regata	Ancho	Formato
15mm	46mm	R25

Material	EPDM 70° NEGRO
----------	----------------

**10002432**

Regata	Alto	Formato
15,8mm	37mm	R30m

Material	EPDM 70° NEGRO
----------	----------------

**10002626**

Regata	Alto	Formato
16mm	38mm	R50m

Material	EPDM 70° NEGRO
----------	----------------

**10003531**

Regata	Ancho	Formato
16,9mm	23,1mm	R50m

Material	NEOPRENO 70° NEGRO
----------	--------------------

**10001666**

Regata	Alto	Formato
18mm	7mm	CR100m

Material	EPDM 70° NEGRO
----------	----------------



10001250		
Regata	Alto	Formato
18mm	20,4mm	R25m
Material	EPDM 70° NEGRO	

100H1496		
Regata	Alto	Formato
18mm	20,7mm	R25m
Material	NBR 70° NEGRO	

10002722		
Regata	Alto	Formato
18mm	44mm	R25m
Material	EPDM 70° NEGRO	

10000935		
Regata	Ancho	Formato
18,4mm	24mm	CR25m
Material	EPDM 70° NEGRO	

10001509		
Regata	Alto	Formato
18,5mm	17mm	CR50m
Material	EPDM 70° NEGRO	

10002561		
Regata	Alto	Formato
19mm	35mm	R25m
Material	EPDM 70° NEGRO	

10001952		
Regata	Alto	Formato
19mm	35mm	CR25m
Material	EPDM 70° NEGRO	

10003348		
Regata	Ancho	Formato
20mm	12mm	CR50m
Material	EPDM 70° NEGRO	

10003436		
Regata	Alto	Formato
20mm	12mm	CR100m
Material	EPDM 70° NEGRO	

10001944		
Regata	Alto	Formato
20mm	22mm	R50m
Material	EPDM 70° NEGRO	

10001902		
Regata	Alto	Formato
20mm	35mm	R25m
Material	EPDM 70° NEGRO	

10000996		
Regata	Alto	Formato
24mm	23mm	R50m
Material	EPDM 70° NEGRO	

10004215		
Regata	Alto	Formato
20mm	25mm	CR50m
Material	EPDM 70° NEGRO	

10002827		
Regata	Alto	Formato
25mm	35mm	R50m
Material	EPDM 70° NEGRO	

10004145		
Regata	Alto	Formato
26mm	20mm	R50m
Material	EPDM 70° NEGRO	

10002390		
Regata	Alto	Formato
30mm	23mm	R50m
Material	EPDM 70° NEGRO	



# EPDM / CEDULAR PERFILES FORMA U

**10002500**

Regata	Alto	Formato
30mm	55mm	R25m

Material	EPDM 70° NEGRO
----------	----------------

**10002506**

Regata	Alto	Formato
30mm	36mm	R25m

Material	EPDM 70° NEGRO
----------	----------------

**10003413**

Regata	Alto	Formato
35mm	20,50mm	CR25m

Material	EPDM 70° NEGRO
----------	----------------

**10002365**

Regata	Ancho	Formato
38mm	50mm	TIRAS

Material	EPDM 70° NEGRO
----------	----------------

**10002397**

Regata	Alto	Formato
40mm	24mm	R29m

Material	EPDM 70° NEGRO
----------	----------------

**10002481**

Regata	Alto	Formato
40mm	48mm	R25m

Material	EPDM 70° NEGRO
----------	----------------

**10001499**

Regata	Alto	Formato
41mm	45mm	TIRAS

Material	EPDM 70° NEGRO
----------	----------------

**10003750**

Regata	Ancho	Formato
50mm	6mm	R25m

Material	EPDM 70° NEGRO
----------	----------------

**10004158**

Regata	Alto	Formato
61mm	8mm	R25m

Material	EPDM 70° NEGRO
----------	----------------

**10003713**

Regata	Alto	Formato
70mm	80mm	TIRAS

Material	EPDM 70° NEGRO
----------	----------------

**10000827**

Regata	Alto	Formato
91mm	11mm	R25m

Material	EPDM 70° NEGRO
----------	----------------

**10000318**

Regata	Alto	Formato
91mm	11mm	R25

Material	EPDM 70° BLANCO
----------	-----------------

**10002220**

Regata	Alto	Formato
101mm	11,5mm	R25m

Material	EPDM 70° NEGRO
----------	----------------



**10000718**

Regata	Alto	Formato
2mm	11mm	CR100m

Material	EPDM CED. 0,65°
----------	-----------------

**10004026**

Regata	Alto	Formato
2mm	13mm	CR100m

Material	EPDM CED. 0,65°
----------	-----------------

**10000721**

Regata	Alto	Formato
3mm	12mm	CR50m

Material	EPDM CED. 0,60°
----------	-----------------

**10000719**

Regata	Alto	Formato
3mm	15mm	CR50m

Material	EPDM CED. 0,75°
----------	-----------------

**10003506**

Regata	Alto	Formato
3mm	15mm	CR100m

Material	EPDM CED. 0,65°
----------	-----------------

**10003931**

Regata	Alto	Formato
3mm	20mm	CR200m

Material	EPDM CED. 0,60°
----------	-----------------

**10000717**

Regata	Alto	Formato
4mm	10mm	CR100m

Material	EPDM CED. 0,60°
----------	-----------------

**10000720**

Regata	Alto	Formato
6mm	12mm	CR50m

Material	EPDM CED. 0,60°
----------	-----------------

**10000722**

Alto	Ancho	Formato
6mm	15mm	CR100m

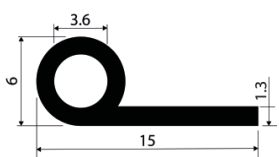

Material	EPDM 70° NEGRO
----------	----------------

**10000723**

Alto	Ancho	Formato
7mm	15mm	CR100m

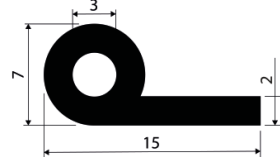

Material	EPDM 70° NEGRO
----------	----------------

**10002540**

Alto	Ancho	Formato
10mm	16mm	CR50m

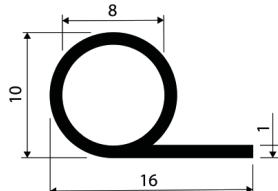

Material	EPDM 70° NEGRO
----------	----------------

**10002541 ADH**

Alto	Ancho	Formato
10mm	16mm	CR50m

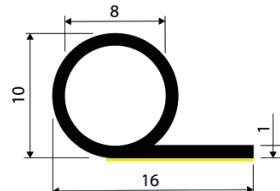

Material	EPDM 70° NEGRO
----------	----------------

**10002768 ADH**

Alto	Ancho	Formato
10mm	16mm	CR50m

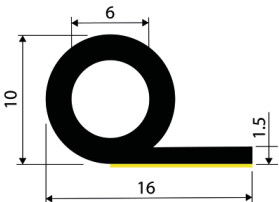

Material	EPDM 70° NEGRO
----------	----------------

**10002769**

Alto	Ancho	Formato
10mm	16mm	CR50m

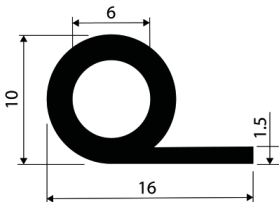

Material	EPDM 70° NEGRO
----------	----------------

**10000114**

Alto	Ancho	Formato
5mm	18mm	CR100m

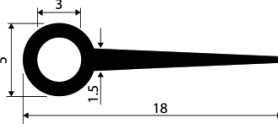

Material	EPDM 70° NEGRO
----------	----------------

**10000690**

Alto	Ancho	Formato
4mm	19mm	CR100m



Material	EPDM 70° NEGRO
----------	----------------

**10000724**

Alto	Ancho	Formato
8mm	20mm	CR50m

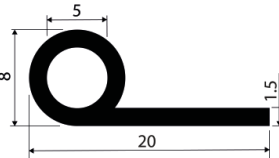

Material	EPDM 70° NEGRO
----------	----------------

**10002578**

Alto	Ancho	Formato
8mm	20mm	CR50m

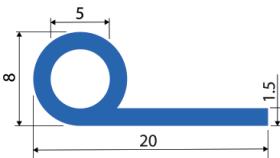

Material	SILICONA 65° AZUL
----------	-------------------

**10000727**

Alto	Ancho	Formato
10mm	25mm	CR50m

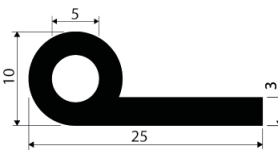

Material	EPDM 70° NEGRO
----------	----------------

**10000731**

Alto	Ancho	Formato
6mm	26mm	CR100m

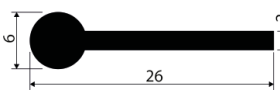

Material	EPDM 70° NEGRO
----------	----------------

**10000725**

Alto	Ancho	Formato
8mm	26mm	CR50m

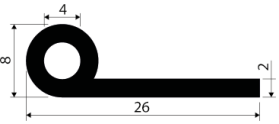

Material	EPDM 70° NEGRO
----------	----------------

**10000732**

Alto	Ancho	Formato
6mm	29mm	CR100m



Material	EPDM 70° NEGRO
----------	----------------

**10000726**

Alto	Ancho	Formato
9mm	29mm	CR50m

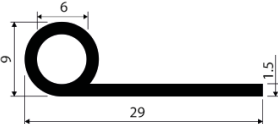

Material	EPDM 70° NEGRO
----------	----------------

**10001035**

Alto	Ancho	Formato
9,6mm	29mm	CR50m

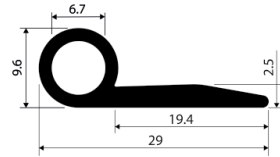

Material	EPDM 70° NEGRO
----------	----------------



10000728		
Alto	Ancho	Formato
10mm	30mm	CR50m
Material	EPDM 70° NEGRO	

10000729		
Alto	Ancho	Formato
12mm	30mm	CR50m
Material	EPDM 70° NEGRO	

10000730		
Alto	Ancho	Formato
13mm	30mm	CR100m
Material	EPDM 70° NEGRO	

1003289		
Alto	Ancho	Formato
25mm	35mm	R25m
Material	EPDM 70° NEGRO	

10002998		
Alto	Ancho	Formato
10mm	36mm	CR100m
Material	EPDM 70° NEGRO	

10000222		
Alto	Ancho	Formato
17mm	40mm	CR25m
Material	EPDM 70° NEGRO	

10001617		
Alto	Ancho	Formato
10mm	43mm	CR50m
Material	SIL. 60° ROJO VIVO	

10003292		
Alto	Ancho	Formato
15mm	45mm	CR50m
Material	EPDM 70° NEGRO	

10004238		
Alto	Ancho	Formato
30mm	50mm	R25m
Material	EPDM 70° NEGRO	

10003147		
Alto	Ancho	Formato
22mm	54mm	R25m
Material	EPDM 70° NEGRO	

10003322		
Alto	Ancho	Formato
30mm	60mm	CR25m
Material	EPDM 70° NEGRO	

10003096		
Alto	Ancho	Formato
25mm	60mm	R25m
Material	EPDM 70° NEGRO	

10002491		
Alto	Ancho	Formato
30mm	65mm	R25m
Material	EPDM 70° NEGRO	

1001674		
Alto	Ancho	Formato
20mm	70mm	R25m
Material	EPDM 70° NEGRO	

10001731		
Alto	Ancho	Formato
35mm	70mm	R25m
Material	EPDM 70° NEGRO	

10002062		
Alto	Ancho	Formato
21,5mm	73,5mm	R25m
Material	EPDM 70° NEGRO	



10001675		
Alto	Ancho	Formato
17,5mm	74mm	CR25m
Material	EPDM 70° NEGRO	

10001787		
Alto	Ancho	Formato
35mm	75mm	CR25m
Material	EPDM 70° NEGRO	

10001585		
Alto	Ancho	Formato
32mm	76mm	R25m
Material	EPDM 70° NEGRO	

10002987		
Alto	Ancho	Formato
25mm	80mm	R12m
Material	EPDM 70° NEGRO	

10002351		
Alto	Ancho	Formato
10mm	90mm	R50m
Material	EPDM 70° NEGRO	

10003503		
Alto	Ancho	Formato
29mm	90mm	R25m
Material	EPDM 70° NEGRO	

10002723		
Alto	Ancho	Formato
40mm	95mm	R10m
Material	EPDM 70° NEGRO	

10003548		
Alto	Ancho	Formato
11mm	100mm	R50m
Material	EPDM 70° NEGRO	

10000225		
Alto	Ancho	Formato
32mm	110mm	CR25m
Material	EPDM 70° NEGRO	



**10003072**

Alto	Ancho	Formato
30mm	25mm	R25m

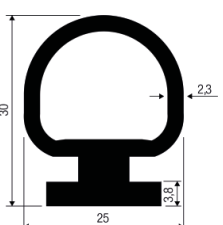

Material	EPDM 70° NEGRO
----------	----------------

**10002398**

Alto	Ancho	Formato
35,5mm	27mm	R30m

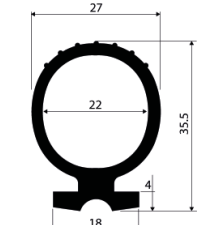

Material	EPDM 70° NEGRO
----------	----------------

**10002429**

Alto	Ancho	Formato
21mm	44mm	R10m

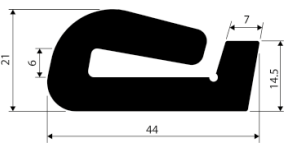

Material	EPDM 50° NEGRO
----------	----------------

**10003433**

Alto	Ancho	Formato
6,7mm	12mm	CR100m

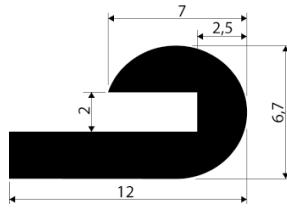

Material	EPDM 70° NEGRO
----------	----------------

**10001752**

Alto	Ancho	Formato
20mm	25mm	R50m

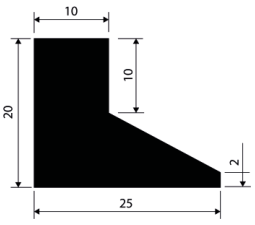

Material	EPDM 70° NEGRO
----------	----------------

**10001770**

Alto	Ancho	Formato
12,75mm	29,8mm	CR50m

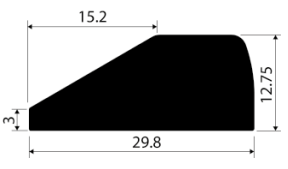

Material	EPDM 70° NEGRO
----------	----------------

**10001516**

Alto	Ancho	Formato
12mm	28mm	CR50m

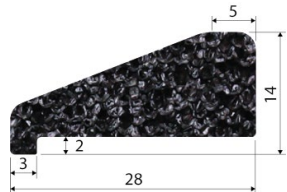

Material	EPDM CED. 0,80°
----------	-----------------

**10001638**

Alto	Ancho	Formato
20mm	30,32mm	CR50m

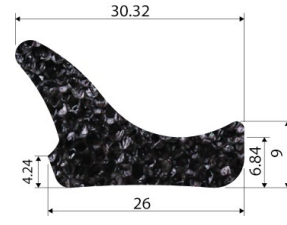

Material	EPDM CED. 0,60°
----------	-----------------

**10002761**

Alto	Ancho	Formato
6,9mm	18mm	CR100m

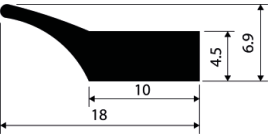

Material	EPDM 70° NEGRO
----------	----------------

**10002751**

Alto	Ancho	Formato
7,6mm	25,5mm	R36m



Material	EPDM 70° NEGRO
----------	----------------

**10001171**

Alto	Ancho	Formato
10mm	35mm	CR50m

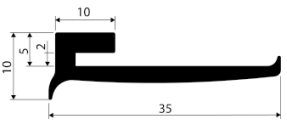

Material	EPDM IGN 70° NEGRO
----------	--------------------

**10002555**

Alto	Ancho	Formato
13mm	52,3mm	R100m

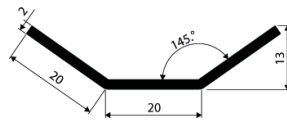

Material	EPDM 70° NEGRO
----------	----------------

**10003276**

Alto	Ancho	Formato
7mm	26,8mm	R25m

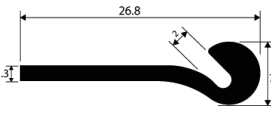

Material	EPDM 70° NEGRO
----------	----------------

**10003260**

Alto	Ancho	Formato
8,86mm	45,3mm	R50m

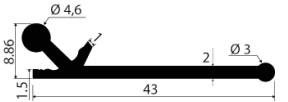

Material	EPDM IGN 70° NEGRO
----------	--------------------

**10002727**

Alto	Ancho	Formato
15mm	21mm	R50m

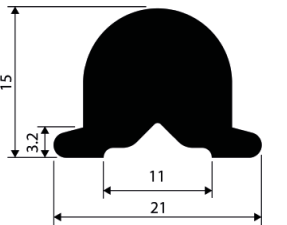

Material	EPDM 70° NEGRO
----------	----------------

**10003265**

Alto	Ancho	Formato
9,5mm	12,5mm	CR100m

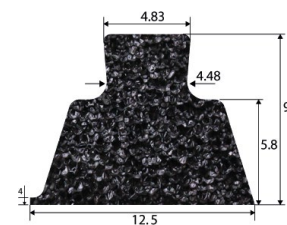

Material	EPDM CED. 0,65°
----------	-----------------

**10000998**

Alto	Ancho	Formato
23mm	30mm	R100m

Material	EPDM 50° NEGRO
----------	----------------

**10000923**

Alto	Ancho	Formato
38,25mm	135,27mm	R25m

Material	EPDM 70° NEGRO
----------	----------------

**10003093**

Alto	Ancho	Formato
36mm	34mm	R25m

Material	EPDM 70° NEGRO
----------	----------------

**10001158**

Alto	Ancho	Formato
12,5mm	58mm	R50m

Material	NBR 70° NEGRO
----------	---------------

**10002523**

Alto	Ancho	Formato
5mm	60mm	CR25m

Material	EPDM 80° NEGRO
----------	----------------

**10001589**

Alto	Ancho	Formato
8,5mm	79mm	R50m

Material	EPDM 70° NEGRO
----------	----------------

**10003210**

Alto	Ancho	Formato
7,5mm	59,5mm	CR50m

Material	EPDM 70° NEGRO
----------	----------------

**10003287**

Alto	Ancho	Formato
10mm	120mm	R25m

Material	EPDM 70° NEGRO
----------	----------------

**10003773**

Alto	Ancho	Formato
4,5mm	28mm	

Material	EPDM 80° NEGRO
----------	----------------

**10000705**

Alto	Ancho	Formato
6mm	19mm	CR100m

Material	EPDM 70° NEGRO
----------	----------------

**10003143**

Alto	Ancho	Formato
2,7mm	6,5mm	CR150m

Material	EPDM CED. 0,65°
----------	-----------------

**10003211**

Alto	Ancho	Formato
5,5mm	25,5mm	CR100m

Material	EPDM 70° NEGRO
----------	----------------

**10003146**

Alto	Ancho	Formato
29mm	17,5mm	TIRAS

Material	EPDM IGN 70° NEGRO
----------	--------------------

**10001061**

Alto	Ancho	Formato
14,5mm	10,9mm	CR200m

Material	EPDM 70° BLANCO
----------	-----------------

**10003973**

Alto	Ancho	Formato
12mm	15mm	TIRAS

Material	EPDM 70° NEGRO
----------	----------------

**10004196**

Alto	Ancho	Formato
22,3mm	32,5mm	TIRAS

Material	EPDM 70° NEGRO
----------	----------------

**10002389**

Alto	Ancho	Formato
6,8mm	13,5mm	CR200m

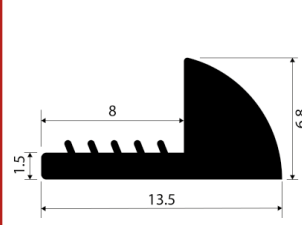

Material	EPDM ING 70° NEGRO
----------	--------------------

**10002165**

Alto	Ancho	Formato
21mm	24mm	R25m

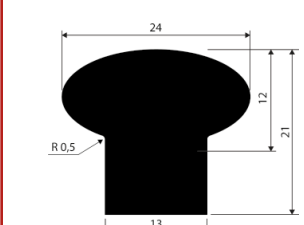

Material	EPDM 70° NEGRO
----------	----------------

**10004205**

Alto	Ancho	Formato
39,4mm	18mm	CR50m

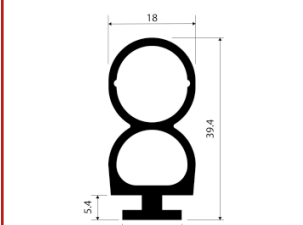

Material	EPDM 70° NEGRO
----------	----------------

**10003862**

Alto	Ancho	Formato
4mm	9,5mm	CR50m

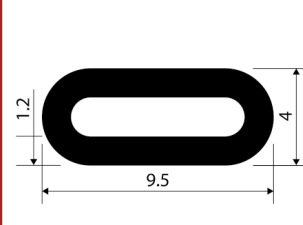

Material	EPDM 70° NEGRO
----------	----------------

**10004302**

Alto	Ancho	Formato
19,5mm	26,3mm	CR50m

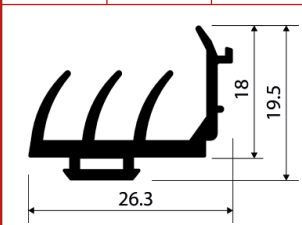

Material	EPDM 70° NEGRO
----------	----------------

**100H1571**

Alto	Ancho	Formato
46,5mm	95mm	TIRAS

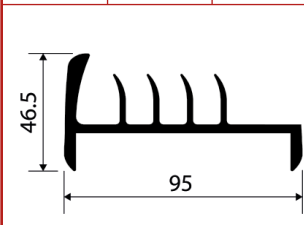

Material	EPDM 70° NEGRO
----------	----------------

**100H1572**

Alto	Ancho	Formato
46,5mm	95,6mm	TIRAS

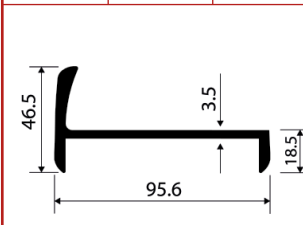

Material	EPDM 70° NEGRO
----------	----------------

**10004290**

Alto	Ancho	Formato
4mm	9,5mm	CR250m

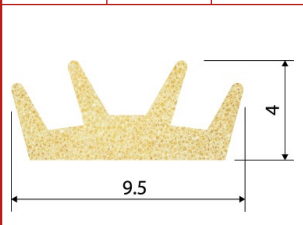

Material	ESP-EPDM 0.65°
----------	----------------

**100H1578**

Alto	Ancho	Formato
20mm	12mm	CR50m

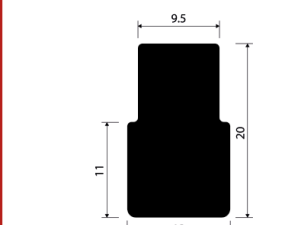

Material	EPDM IGN 70° NEGRO
----------	--------------------

**10004291**

Alto	Ancho	Formato
31mm	20mm	CR100m

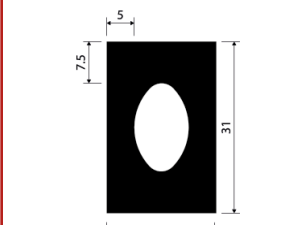

Material	EPDM 70° NEGRO
----------	----------------

**10001753**

Alto	Ancho	Formato
4,6mm	25mm	CR100m

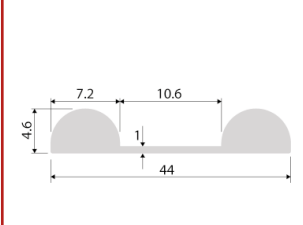

Material	SILICONA 65° TRANS.
----------	---------------------

**10001989**

Alto	Ancho	Formato
8mm	8mm	CR100m

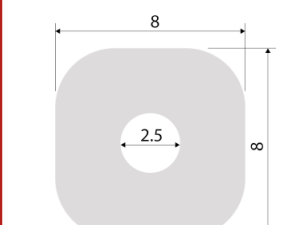

Material	EPDM 70° BLANCO
----------	-----------------

**10001990**

Alto	Ancho	Formato
9mm	9mm	CR100m

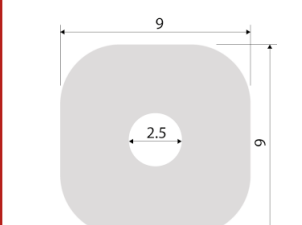

Material	EPDM 70° BLANCO
----------	-----------------

**10001991**

Alto	Ancho	Formato
10,5mm	10,5mm	CR100m

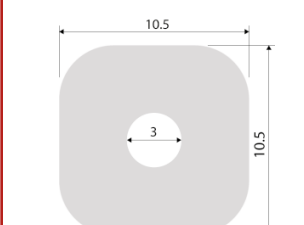

Material	EPDM 70° BLANCO
----------	-----------------

**10001992**

Alto	Ancho	Formato
11mm	11mm	CR100m

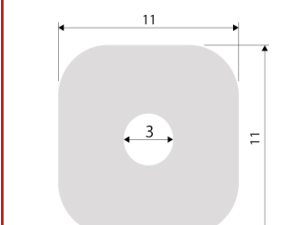

Material	EPDM 70° BLANCO
----------	-----------------

**10001993**

Alto	Ancho	Formato
12,5mm	12,5mm	CR100m

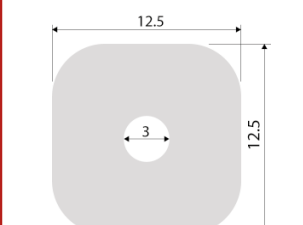

Material	EPDM 70° BLANCO
----------	-----------------

# Comprometidos con la calidad

ISO 9001 | ISO 14001 <<

EN 45545 | FDA 177.2600 | DVG WW270 | EN 681-1 | ACS | VW281 | UNE <<

Atención personalizada | Calidad | Tecnología | Piezas a medida <<



## Comprometidos con el cliente

>> Atención personalizada | Calidad | Tecnología

>> Monitorización del proceso | Piezas a medida